

Service Experience 2008, MAN B&W Engines ME/ME-C and MC/MC-C Engine Series

Contents:

Introduction

Update on Service Experience, ME/ME-C Engine Series

- Hydraulic cylinder unit (HCU)
- Multi purpose controller (MPC)
- Hydraulic power supply (HPS)
- Servo oil system

Update on Service Experience, MC/MC-C Engine Series

- Condition based overhaul (CBO) of pistons
- CBO of exhaust valves
- CBO of bearings
- Time between overhaul (TBO) for turbochargers

Conclusion

MAN Diesel • Copenhagen, Denmark

Service Experience 2008, MAN B&W Engines ME/ME-C and MC/MC-C Engine Series

Introduction

The number of electronically controlled engines in service continues to grow and, at the time of writing, more than 500 engines are on order or in service.

At the end of 2007, the first S40ME-B engine was prototype-tested at STX in Korea, Fig. 8.1. These tests mark the beginning of an era where the full potential of the electronic fuel injection with “rate shaping” (or “injection profiling”) is utilised on production engines giving a very attractive NO_x/SFOC relationship.

At the beginning of January 2008, the first four LNG carriers with 2 x 6S70ME-C engines (Fig. 8.2) were in service. During 2008, this number will increase to 20 vessels.

In addition to the service experience update for the ME/ME-C engine series, this paper will describe the recent service experience relating to conventional mechanical issues of MAN B&W two-stroke engines. The condition-based overhaul (CBO) concept and an update on monitoring systems will also be given.



Fig. 8.1: 6S40ME-B engine



Fig. 8.2: LNG carrier with 2 x 6S70ME-C engines

Update on Service Experience, ME/ME-C Engine Series

At the end of 2007, 130 ME/ME-C engines were in service. The reporting will be divided into the various sub-systems of the ME/ME-C engines. These are the hydraulic cylinder unit (HCU), the multi purpose controller (MPC), the hydraulic power supply (HPS) and the servo oil system.

Hydraulic cylinder unit (HCU)

For the HCU, we will concentrate on two main topics, i.e. the ME control valves and the exhaust valve actuator system.

ME control valves

ELVA/ELFI valves (Curtiss Wright supply)

ELVA/ELFI configuration (one control valve for exhaust valve actuation and another control valve for fuel injection control) are in service on 20 plants. For the on/off ELVA valve, a modified high-response valve is undergoing service testing. When this service testing is concluded, the 20 plants will be updated and service issues with the ELVA/ELFI configuration will then be solved.

FIVA Valve (Curtiss Wright version)

The feedback loop of the FIVA valve position control, Fig. 8.3, has caused untimed injection and untimed exhaust valve operation owing to various reasons. These reasons are related to the FIVA valve itself in some cases, and in other cases to the part of the feedback loop in the multi purpose controller (MPC), see multi purpose controller chapter.

In the original version, the electronics on the printed circuit board (PCB) in the Curtiss Wright FIVA valve showed thermal instability causing untimed actuation of the valve. The reason was an analogue voltage regulator generating

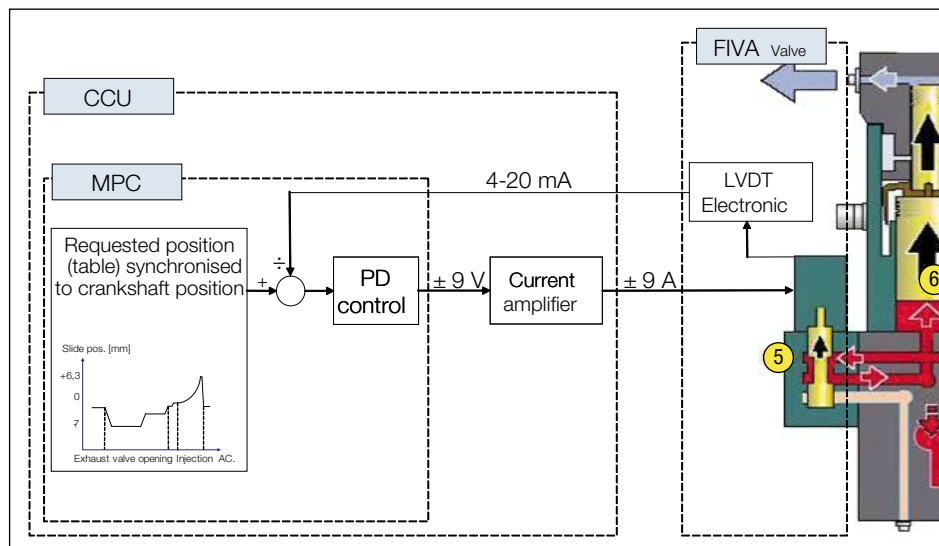

Fig. 8.3: FIVA valve position control

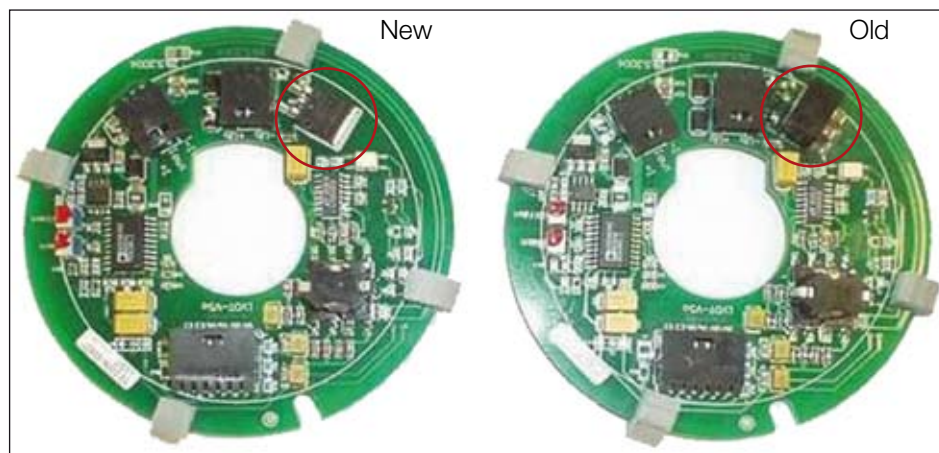

Fig. 8.4: FIVA valve feedback failure: exchange of analogue voltage regulator with switch mode voltage regulator

an excessive amount of heat raising the temperature by 35°C on the PCB. In some cases, this caused a temperature shutdown of the LVDT converter in the feedback loop, resulting in the above-described unstable function of the FIVA valve. The solution was to exchange the analogue voltage regulator with a switch mode regulator, Fig. 8.4. Hereby, the temperature of the PCB was lowered by approx. 35°C.

Furthermore, in order to safeguard against untimed movement of the FIVA main slide due to an erroneous feed-

back signal, improved supervision is introduced by new software, see multi purpose controller chapter.

In 2007, we experienced a cylinder cover lift twice on testbed with 6S70ME-C engines. The reason for these incidents was untimed movement of the FIVA valve main slide owing to a drilling chip left inside the main slide during production, Fig. 8.5. After discovering this production mistake, we have, together with the sub-suppliers, cleaned/re-machined approx. 500 main slides to avoid loose drilling chips inside the FIVA valves.

Fig. 8.6 gives an explanation of what happens if a loose drilling chip is stuck between the pilot slide and the main slide.

Fig. 8.6 (left hand side) shows the valve in balance. This means that the constant pressure on the bottom of the main slide is balanced by a pressure creating a similar force in downward direction, thus keeping the slide in neutral ("zero") position.

In order to open the exhaust valve or to stop fuel injection (Fig. 8.6, centre), the pilot slide should be moved downward, thereby increasing the pressure on the top of the main slide and moving the main slide downward. This will result in exhaust valve opening or stop of fuel injection.

When the pilot slide is moved upward (Fig. 8.6, right hand side), pressure on the top of the main slide is decreasing and the main slide is moved upward enabling closure of the exhaust valve or fuel injection. If a drilling chip is stuck in between the pilot and the main slide when the exhaust valve is closing, there is a risk of fuel injection just after closing of the exhaust valve. This will create an excessive pressure build-up in the combustion chamber and a risk of cylinder cover lifting. This was the cause

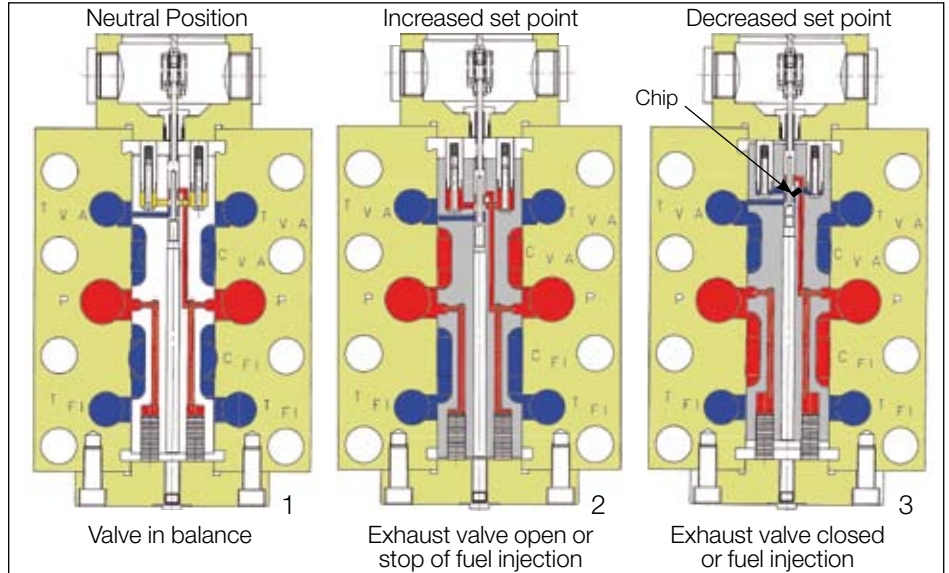

Fig. 8.6: CWAT FIVA valve: Movement of pilot valve and main slide

of the two cylinder cover lifts on the 6S70ME-C engines on testbed in 2007.

FIVA Valve (MAN B&W version)

During 2007, the first vessels with MAN B&W FIVA valves controlling ME engines went into service.

The MAN B&W FIVA valve can be seen in Fig. 8.7. It consists of a valve main body on which the Parker pilot valve and the H. F. Jensen feedback sensor are mounted. For the Parker valve, we

have seen a number of units failing because of:

- A: Broken bushing for the pilot slide, Fig. 8.8a. This item was rectified during the prototype testing period
- B: Earthing failure owing to damage of a flexible wire strip inside the valve, Fig. 8.8b
- C: Malfunction owing to failing operational amplifier, Fig. 8.8c

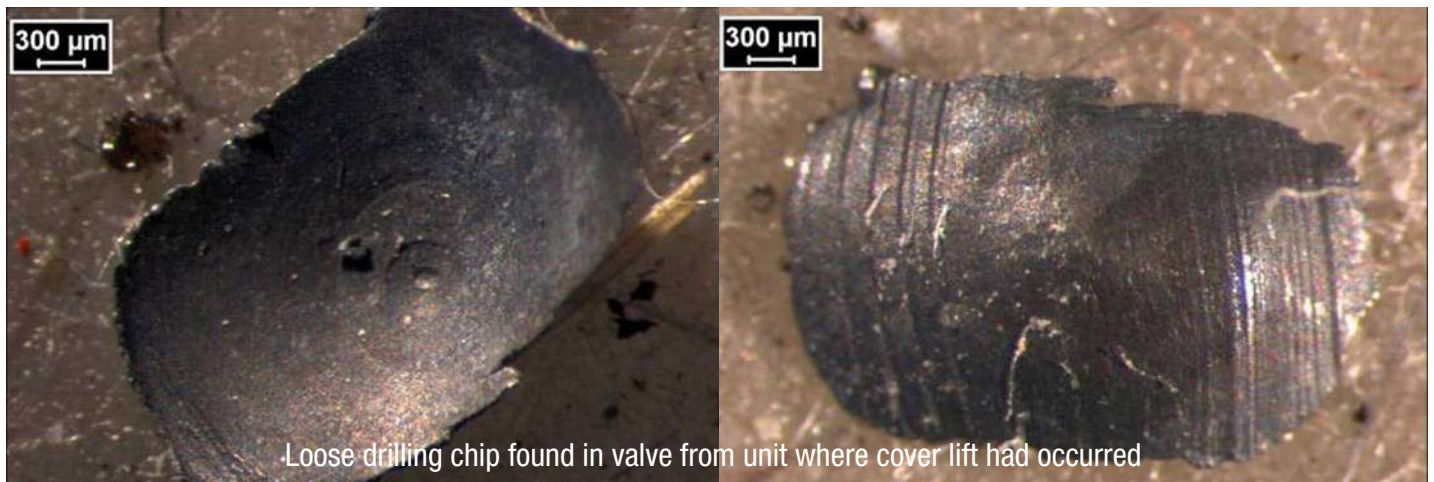

Fig. 8.5: CWAT FIVA valve: chips found in main slide

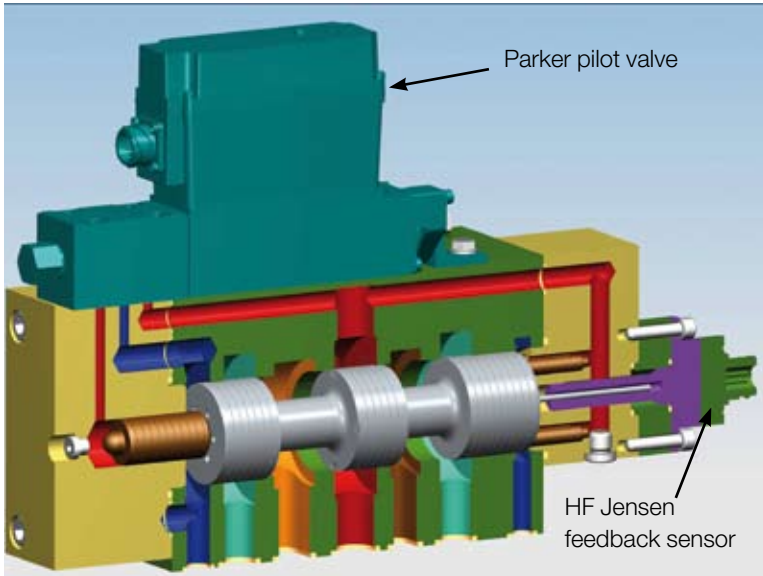

Fig. 8.7: MAN B&W FIVA valve

- A: Breakage of the rod in the sensor. The rod in the sensor has been redesigned, Fig. 8.9a
- B: Broken or loose connection between the print board and the external connector (type: Canon), Fig. 8.9b. Redesign of the connection has solved the problem.

In parallel with solving teething problems with the Parker pilot valve and the H. F. Jensen feedback sensor, other makes of pilot valves and feedback sensors are being tested.



Parker valves with certain serial numbers have been replaced in service.

With respect to the H. F. Jensen feedback sensors, we have experienced two different problems:

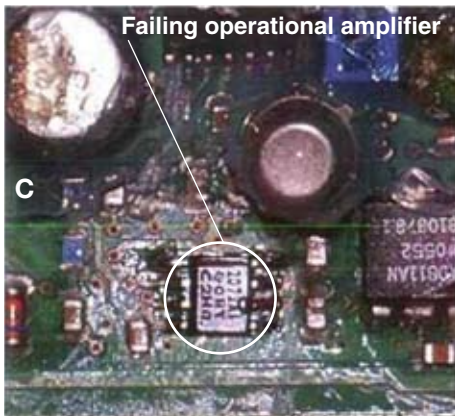
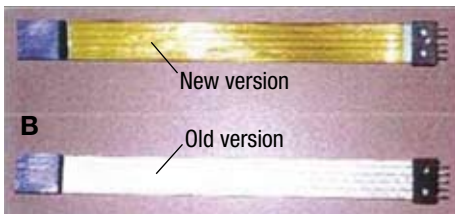

Fig. 8.8a: Broken bushing, b: Damaged wire strip, c: Parker valve

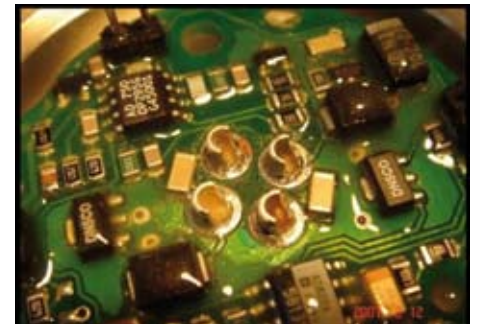

Fig. 8.9b: Connector breakdown, H.F. Jensen feedback sensor

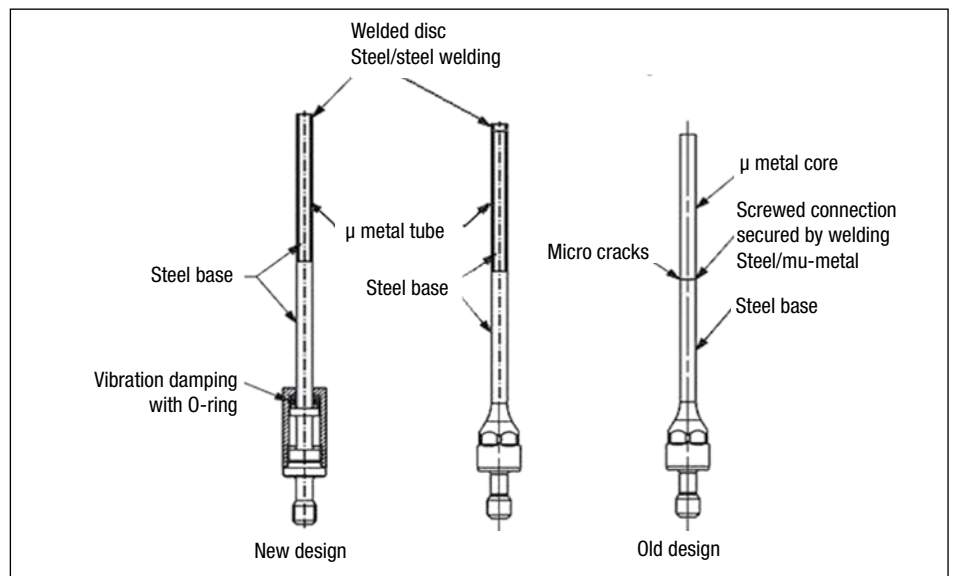

Fig. 8.9a: Redesign of rod for sensor in H.F. Jensen feedback sensor

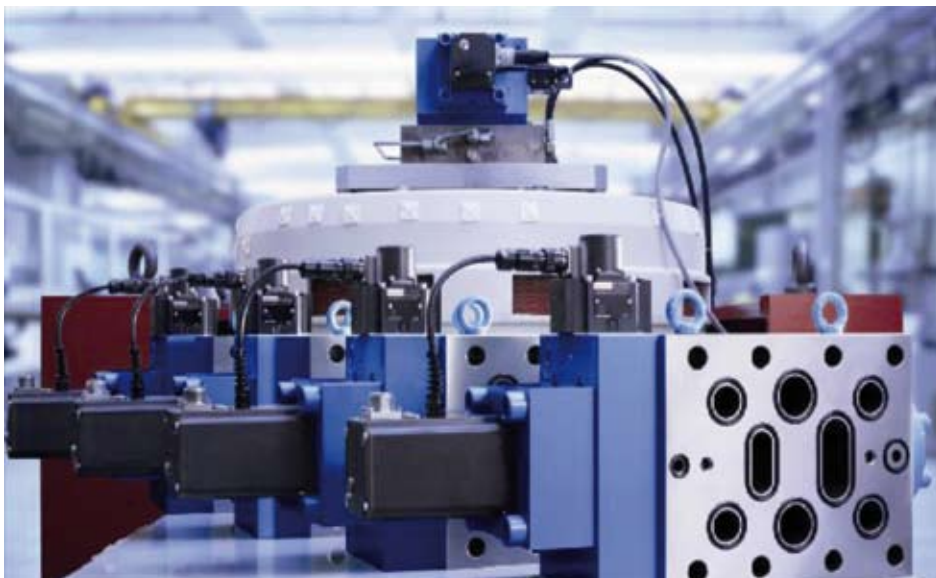

Fig. 8.10: Bosch Rexroth FIVA

FIVA Valve (Bosch Rexroth version)

Service tests of the Bosch Rexroth FIVA valve, Fig. 8.10, on a 12K98ME have been concluded successfully. Bosch Rexroth FIVA valves are now the third alternative for control valves for the present ME engine series.

Cavitation in the exhaust valve actuation system

Cavitation in the exhaust valve actuation system has been seen in the exhaust valve top part, Fig. 8.11a, as well as in the exhaust actuator top cover, Fig. 8.11b.

Furthermore, damage to the oil inlet non-return valves on the actuator top cover indicates excessive pressure fluctuations in the exhaust valve actuation system.

An orifice in the drain line from the FIVA valve, Fig. 8.12, has been introduced to reduce the acceleration of the actuator piston and hereby eliminating cavitation on the actuation side.

At the time of writing, we are monitoring cavitation development after the introduction of the orifice in the FIVA return line. However, in parallel, we are testing further modifications:

A: Reduced braking of the exhaust valve by introduction of an orifice (small hole) in the damper piston, Fig. 8.13.

B: Low-pressure oil supply in the top of the exhaust valve, Fig. 8.13. It is considered to move one of the low-pressure supplies on the actuator, Fig. 8.14, to the top of the exhaust valve.

Whether (A) or (B), or both, is necessary to completely eliminate cavitation damage will be decided in the coming months.

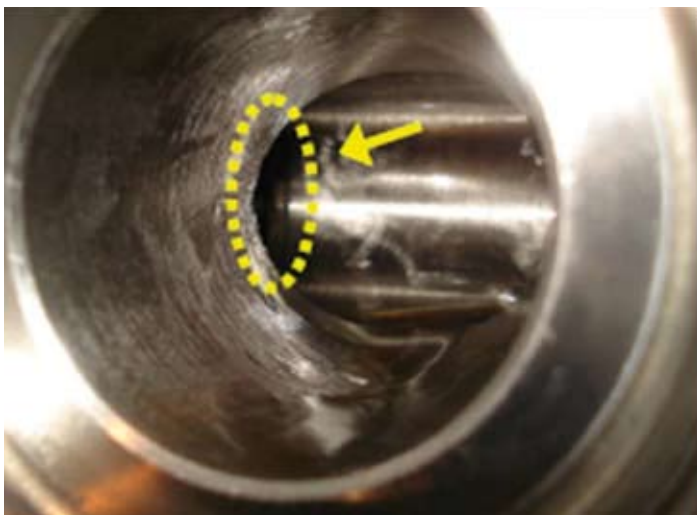
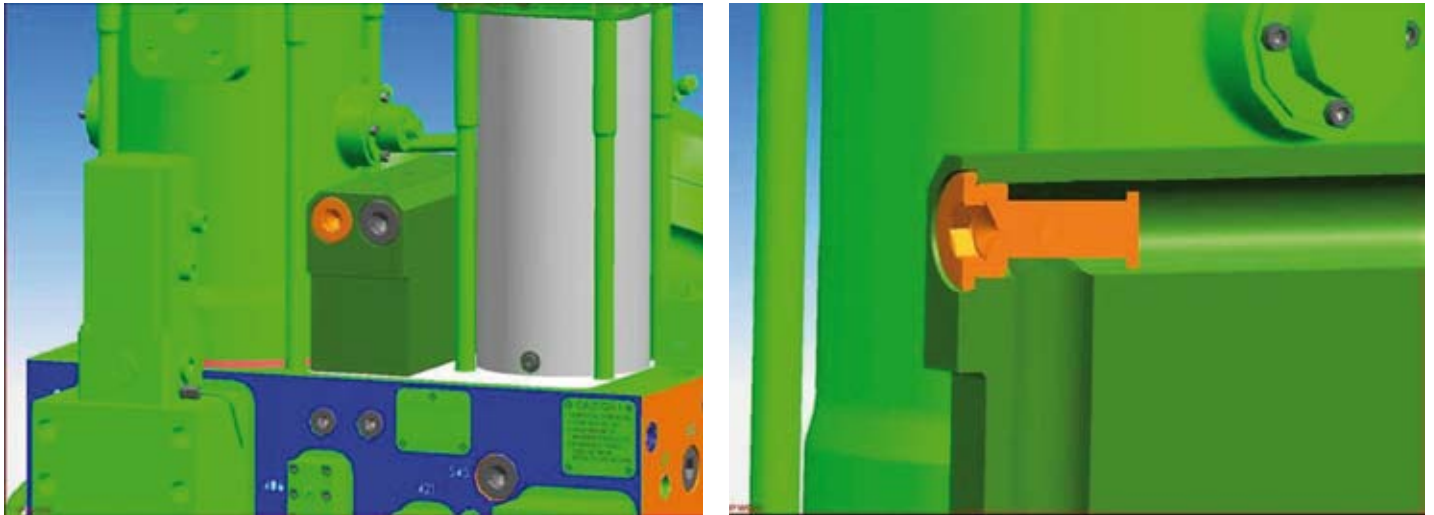

Fig. 8.11a: Cavitation in exhaust valve top part



Fig. 8.11b: Cavitation in exhaust actuator top cover



Introduction of ring orifice corresponding to a 20 mm orifice in the hydraulic system for exhaust valve on K98ME-C

Fig. 8.12: Orifice in the drain line from the FIVA valve

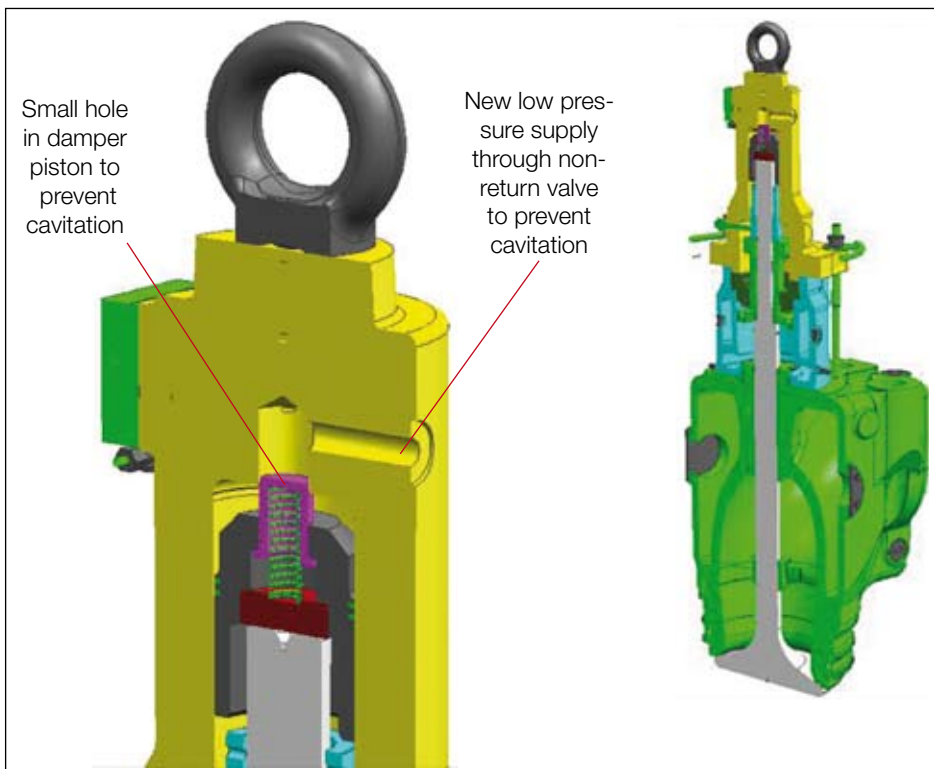

Fig. 8.13: Exhaust actuation system, scheduled test rig tests

Multi purpose controller (MPC)

In 2007, we experienced one severe case of cylinder cover lift on a 6S60ME-C engine in service. After investigations into the parts involved on the cylinder unit in question, it was concluded that the reason was an error in the feedback loop for the FIVA control, Fig. 8.3. However, in this case the error was in the MPC part of the feedback loop. A loose/broken connection in the feedback circuit of the MPC was found during the investigation, see Fig. 8.15.

Countermeasures in this relation were divided into three parts.

Firstly, a circular letter warning against a specific alarm sequence was issued in order to exchange MPCs with similar potential defects. This circular letter was sent to all operators of ME engines.

Secondly, it was concluded from tests that the reason why the error in the feedback loop of the MPC caused an untimed injection was that the feedback signal froze on a low value. When the closed loop control tried to rectify the position of the main slide in the FIVA valve, it moved the main slide towards

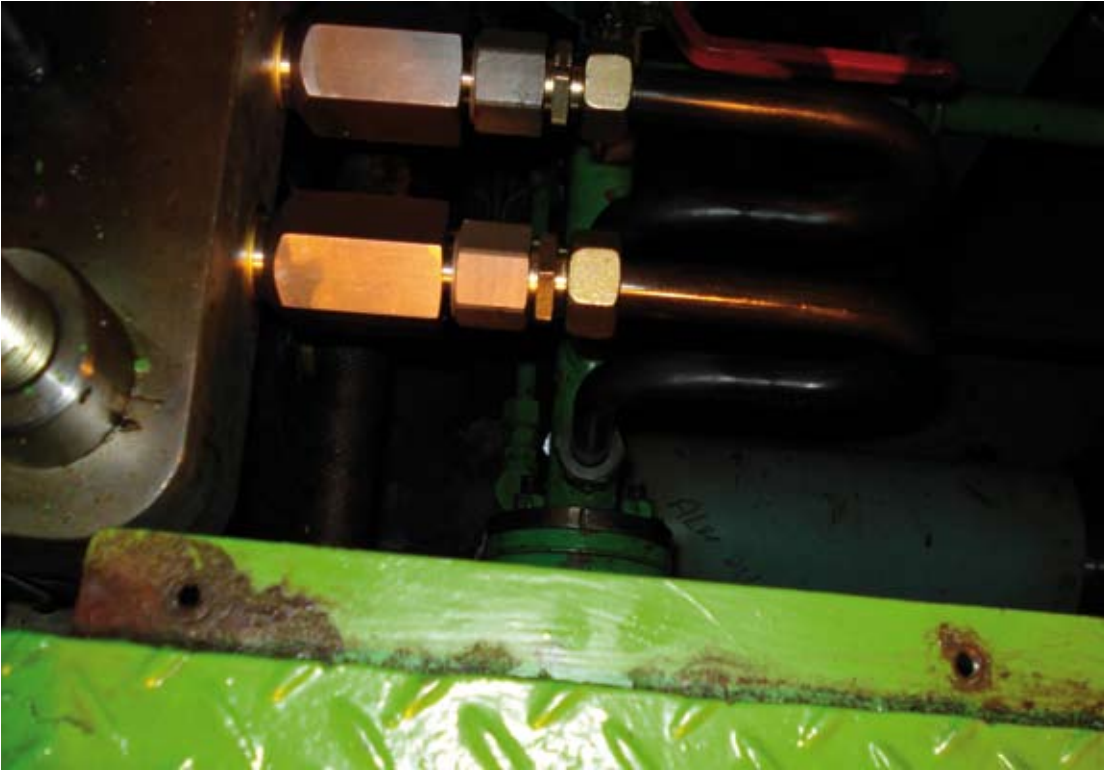

Fig. 8.14: Non-return valves in low pressure supply lines

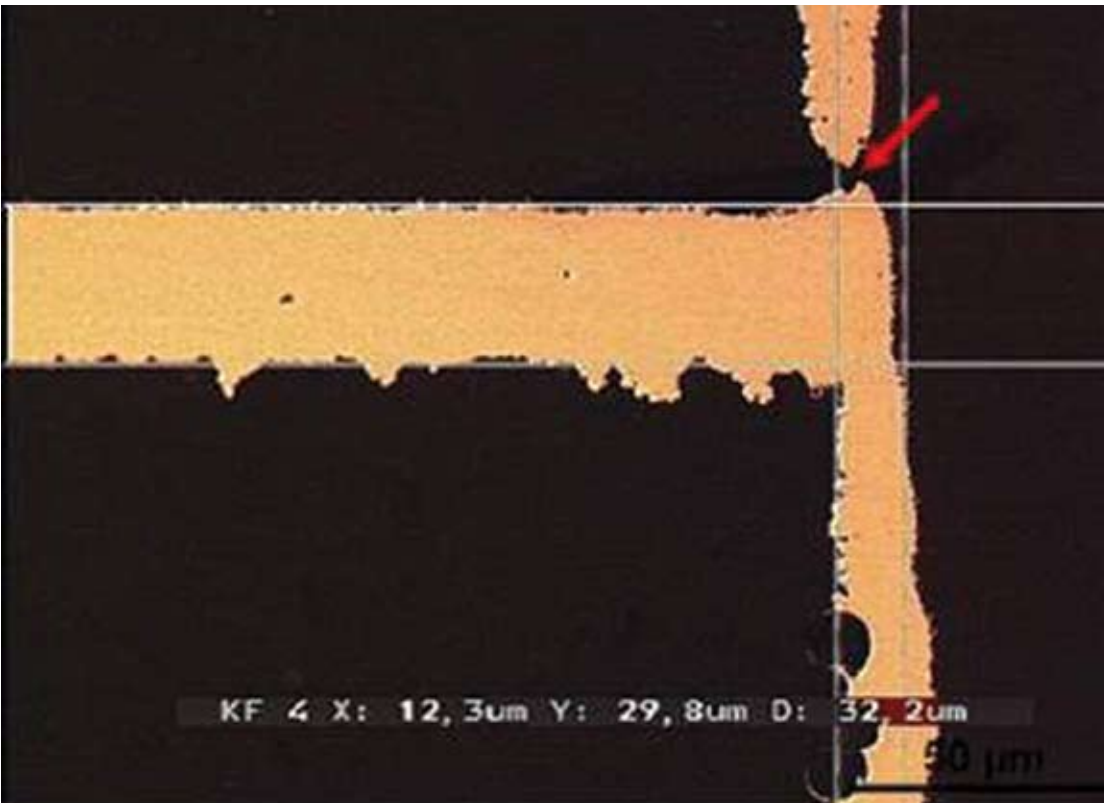

Fig. 8.15: Broken/loose connection in the MPC

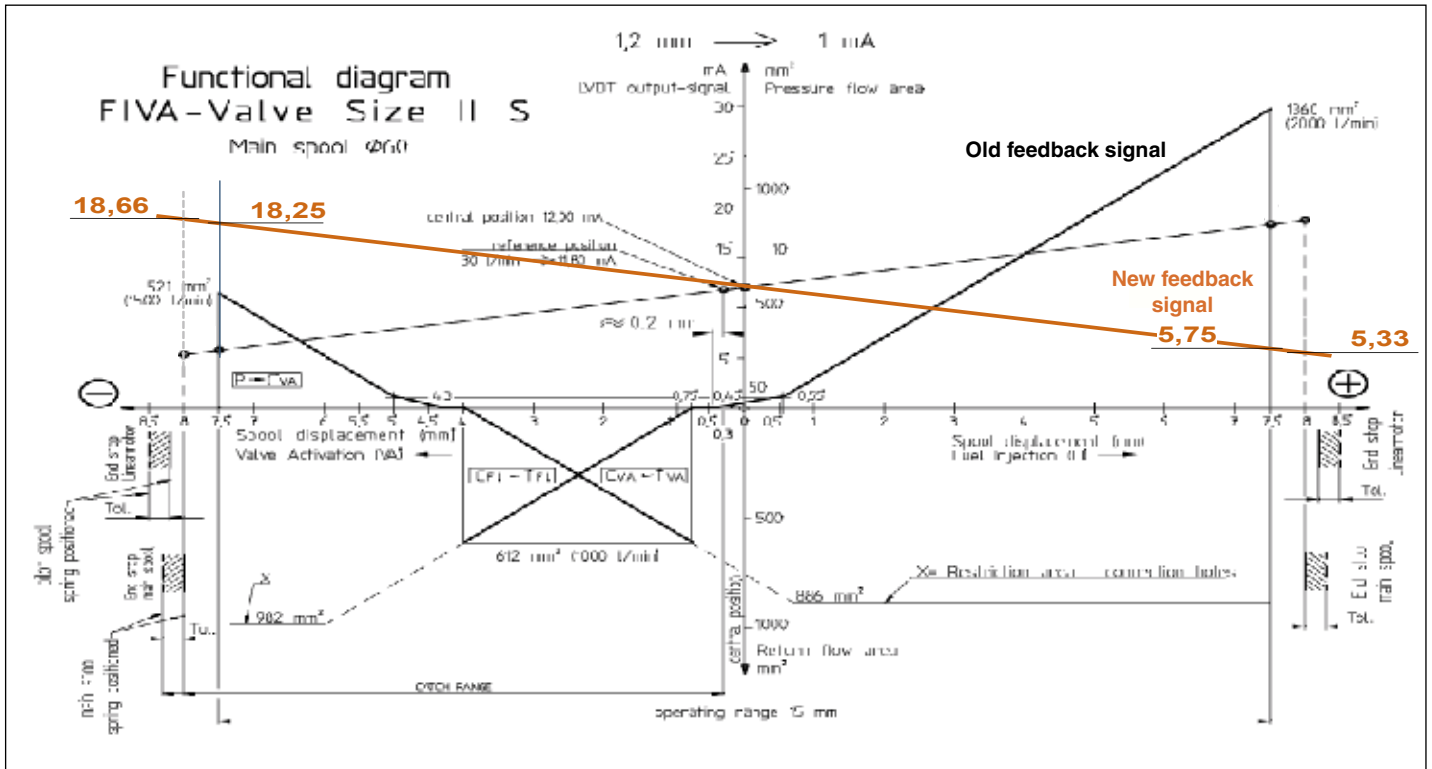

Fig. 8.16: FIVA valve flow area diagram

fuel injection and continued to do so until injection (untimed) was accomplished. This was done because of the frozen low-value feedback signal.

Based on this knowledge, it was decided to invert the feedback signal, Fig. 8.16. By doing this, a frozen low value feedback signal will result in a FIVA main slide movement towards untimed opening of the exhaust valve. This is considered to be “failing into safe mode”.

Thirdly, in order to safeguard further against similar incidents, a new software version with closer supervision of the feedback signal [1] and additional supervision of the fuel plunger movement [2] has been introduced, Fig. 8.17. Control processes including the supervisions [1] and [2] are seen in Fig. 8.18.

All ME engines in service have been or will be updated with the above countermeasures.

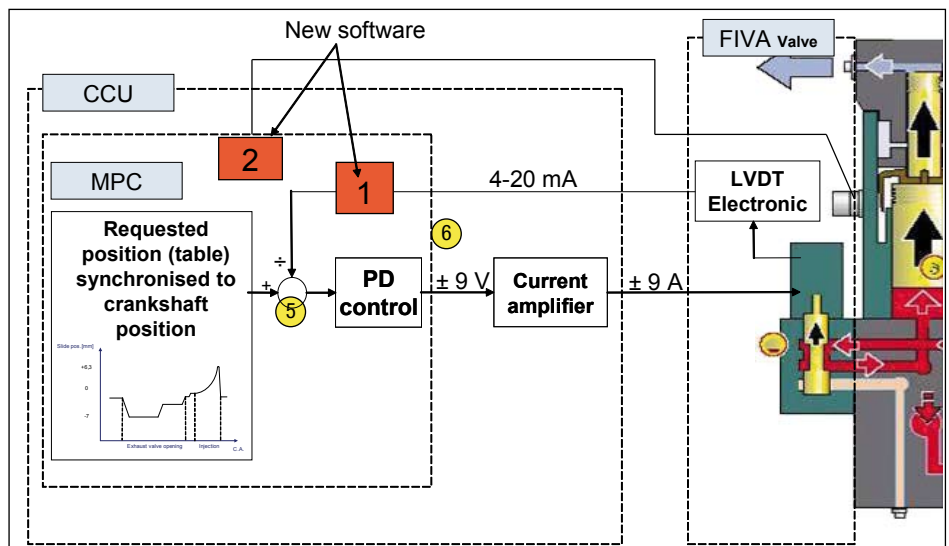

Fig. 8.17: FIVA valve position control

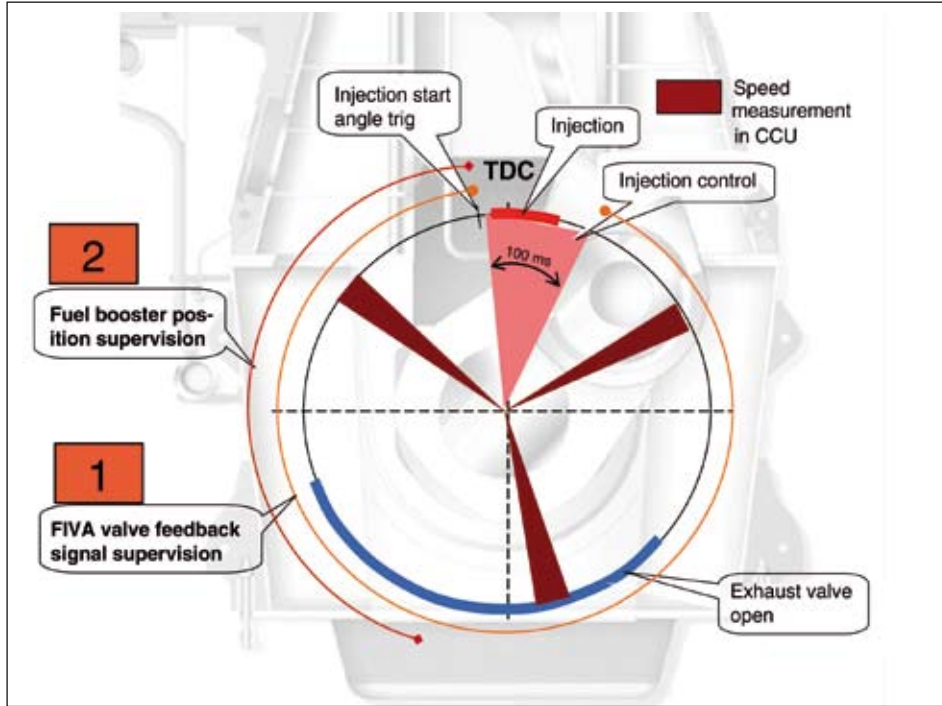

Fig. 8.18: Crankshaft related control processes

Servo oil system

For the present ME engines, two alternative servo oil systems are available:

- A: A standard system where engine system oil is processed through a 6-10 μm full-flow fine filter and then led into the hydraulic pumps of the HPS.
- B: An optional system where a separate servo oil system with a separate tank system is used, Fig. 8.20. The oil is cleaned by a cleaning unit (filter or purifier) mounted on the separate oil tank.

During 2007, we experienced one case of severe contamination of the servo oil system owing to a breakdown of the ship side transfer pumps. This happened on an installation equipped with a separate servo oil system (B).

Hydraulic power supply (HPS)

In 2006, we experienced a breakdown of the bearings in an HPS on a 12K98ME engine. A design review was initiated and modifications were implemented, both for new engines and for engines in service. After this incident we have not seen further incidents relating to the HPS bearing/bushing design on the ME engines.

For a series of the first S70ME-C plants, the chain wheel and gear wheel assembly on the HPS common shaft has shown to be under-dimensioned, Fig. 8.19. An upgrade of the bolt connections has been introduced on the concerned vessels in service.

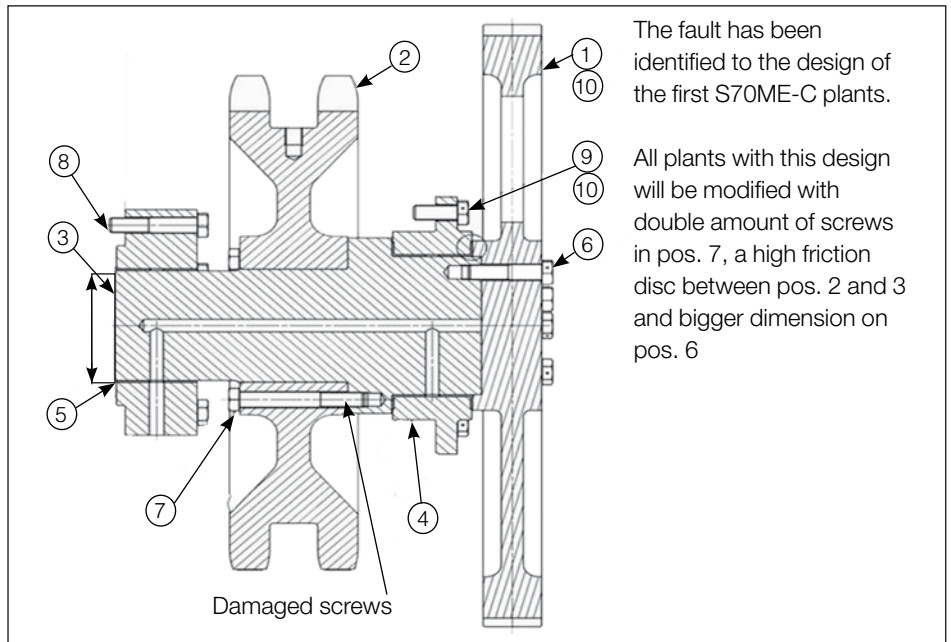

The fault has been identified to the design of the first S70ME-C plants.

All plants with this design will be modified with double amount of screws in pos. 7, a high friction disc between pos. 2 and 3 and bigger dimension on pos. 6

Fig. 8.19: S70ME-C assembly of shaft for hydraulic pump

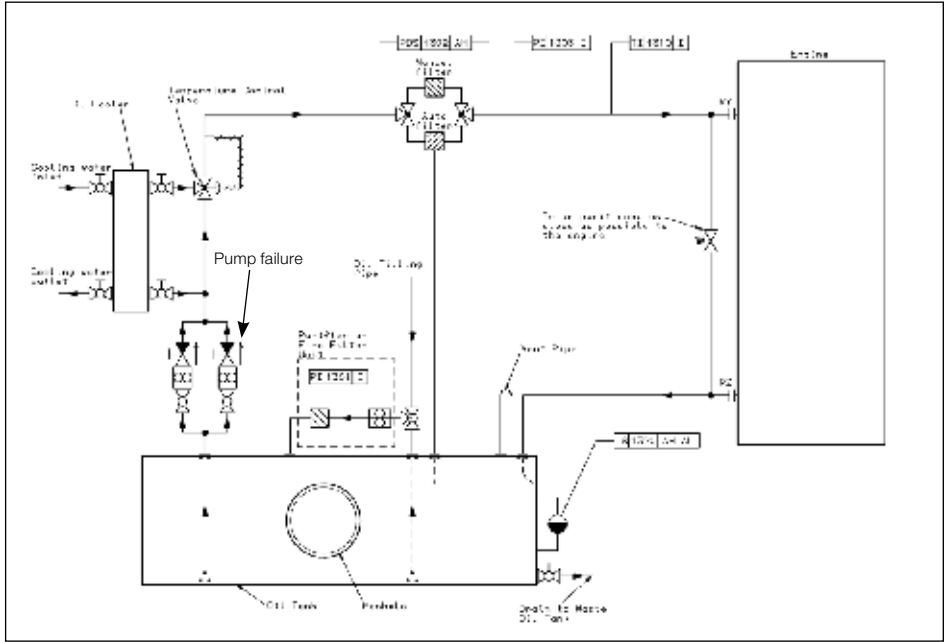

Fig. 8.20: Separate hydraulic oil system, initial version



Fig. 8.21: Breakdown of transfer pumps

Apparently, the screw type pumps produced the contaminating products rather quickly and, therefore, a lot of debris ended up inside the ME control valves, see Fig. 8.21.

After this incident, we have revised our specification for the separate servo oil system, Fig. 8.22. The important change is that a 6 µm full-flow fine filter has been introduced, also on the separate servo oil system.

For engines in service with a separate servo oil system, we recommend to add a “water-in-the-oil monitor”, connect the oil temperature measurement to the alarm system and install a metal detector just before the hydraulic power supply.

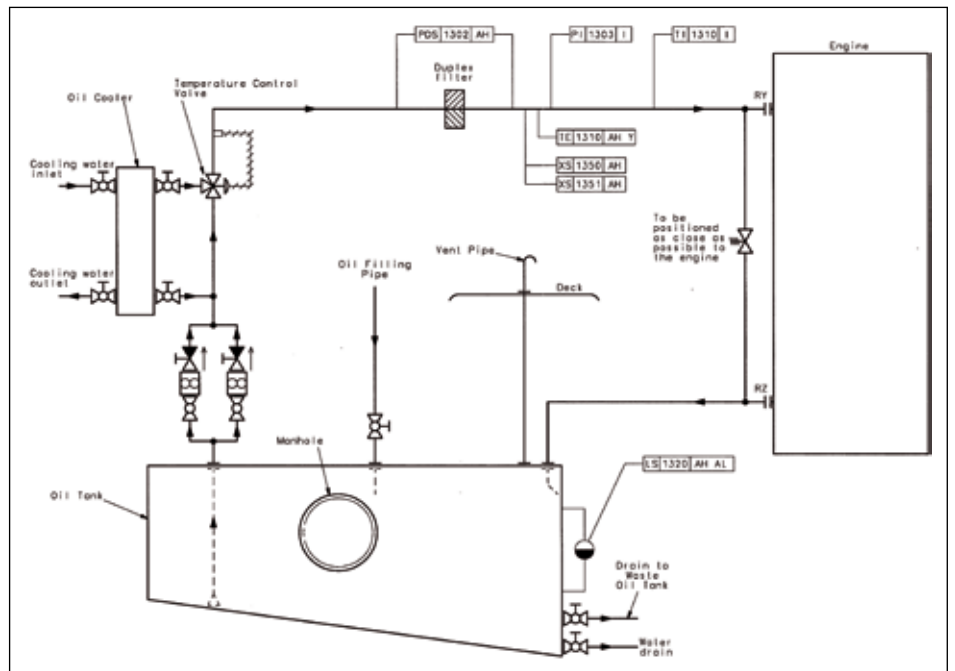

Fig. 8.22: Separate hydraulic oil system, updated version

Update on Service Experience, MC/MC-C Engine Series

In the following, we will describe the recent service experience on the MC/MC-C engine series, with focus on condition based overhaul (CBO) and update on monitoring systems. CBO is of course also relevant and possible for ME/ME-C engines.

Condition based overhaul (CBO) of pistons

The experience with our engines with the latest updated combustion chamber design, i.e. with Oros shape and the latest piston ring design, slide fuel valves and optimised temperature levels, counts more than seven years of operation. Against this background, we have gained valuable knowledge about the need for piston overhauls compared with earlier experience.

The “Guiding Overhaul Interval” for pistons, previously set to 12-16,000 hours, appears to have been set too conservatively. Normally, the need for piston overhaul does not arise until much later, and extensions up to 32,000 hours are possible. However, the fact is that the scatter is large, and many factors are decisive for the need for overhaul.

This calls for a CBO strategy, the objective being to obtain the highest number possible of safe running hours. Preferably, overhauling should only be carried out when necessary.

The most important factor in a CBO strategy is the evaluation of the actual condition, by means of regular scavenge port inspections and logging of wear and hot corrosion. All the decisive factors for piston overhaul can be checked via inspections through the scavenge air ports.

The most important factors for piston overhauls are, Fig. 8.23:

- Piston ring wear
- Max. amount of hot corrosion of piston top allowed on the centre part (where it is normally highest) is 9/12/15 mm on, respectively, 80/90/98-bore engines
- Ring groove clearance
Max. recommended clearance is 1.0 mm on the 80 and 90-bore engines, and 1.1 mm on 98-bore engines
- Sticking, broken or collapsed piston rings or leaking pistons
- Macro-seizures on piston ring running surfaces.

Inspection and logging of the actual cylinder condition and wear should be performed regularly to become familiar with the wear-and-tear development in the cylinder. At the beginning, intervals

should be short, e.g. every second to third week. The intervals can be prolonged as confidence builds up.

The following factors should be measured and recorded:

- Top piston ring wear, defined by measuring the remaining depth of the CL grooves.
- Ring groove clearances, measured with a feeler gauge.
- Estimated piston burnings on large bore engines, measured by means of a template via the scavenge ports.

Our standard sheets “Cylinder Condition Report” and “Inspection through Scavenge Ports” can be used, forming the ideal documentation for later review and for making trend curves for future wear forecasts, Fig. 8.24.

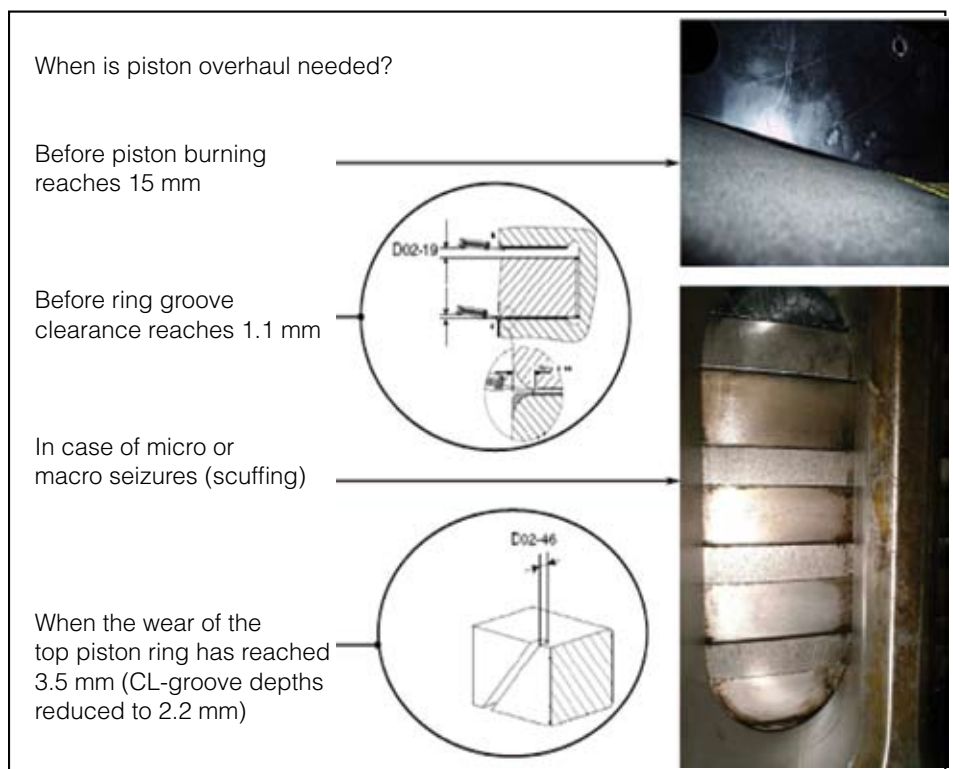

Fig. 8.23: K98 example. The four (4) important factors for piston overhaul

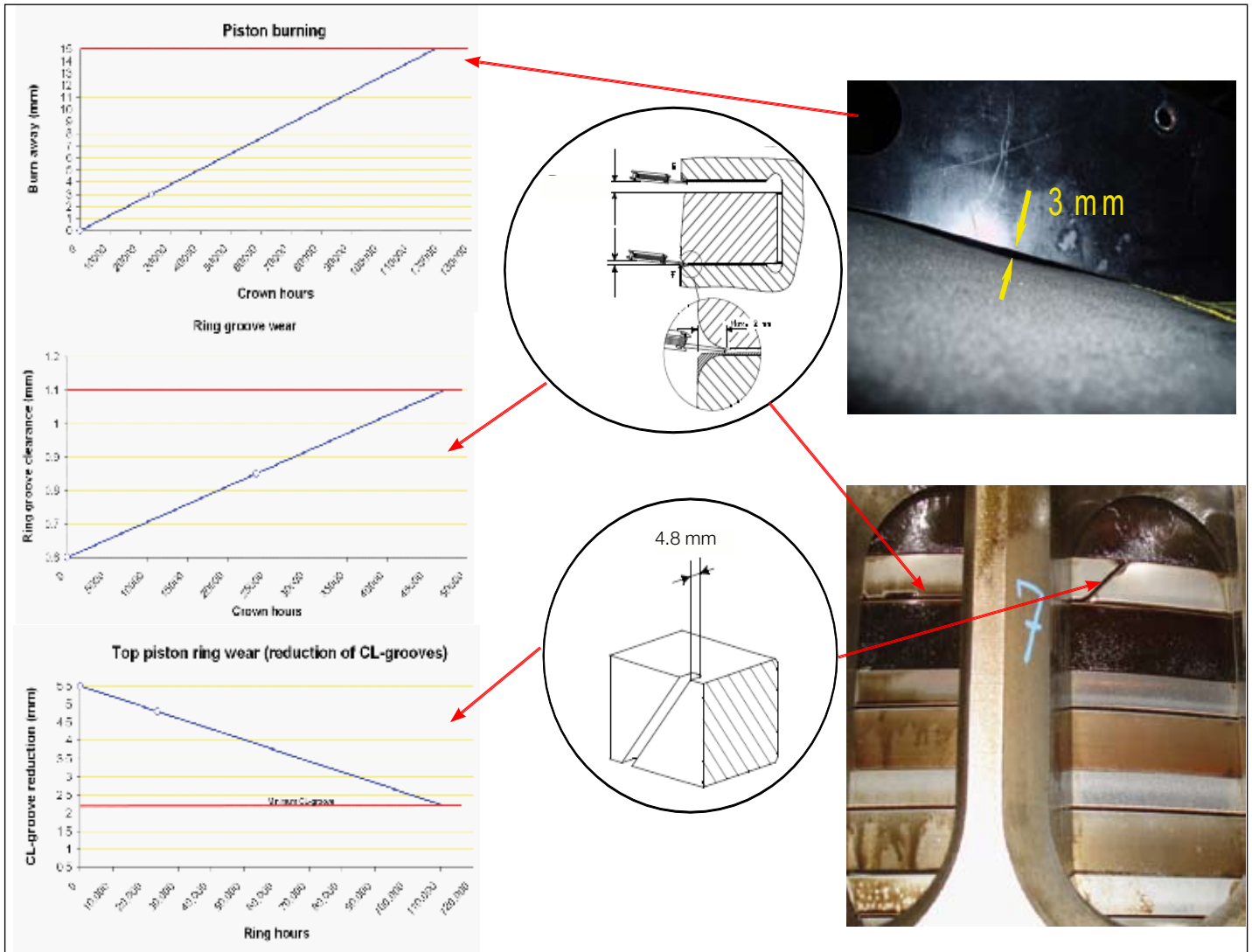

Fig. 8.24: 10K98MC-C, unit no. 7, at 23,500 hours without overhaul. The condition does not call for piston overhaul

The running surfaces of the piston rings are the best indicators of the cylinder condition in general. If the ring surfaces appear to be in good condition and free from scratches, micro or macro-seizures, the liner will also be in good condition, Figs. 8.25-8.30.

Figs. 8.25-8.27 describe conditions of the new cermet coated ring packages with alu-coat running-in. Figs. 8.28-8.30 describe the conditions of the alu-coated ring packages.

Conversely, if the liner appears damaged by active seizures (if the wave-cut pattern has disappeared on the lower cylinder part visible through the ports), the rings will also be affected, and most likely the unit has to be overhauled. As mentioned above, the wear on the top piston rings can be determined by measuring the remaining depth of the CL grooves using a Vernier gauge, but the wear can also be estimated visually simply by checking the size of the remaining rounding on the upper and lower edges of the running surfaces.

From new, the rounding has a radius of 2 mm on 80/90/98-bore engines.

Thus, a simple visual inspection through the scavenge ports confirming that the rounding is still visible or partly visible is an indication that the wear limit has not been reached, and that many more hours are left before piston overhaul is necessary. For further information, we refer to our Service Letter SL07-483.

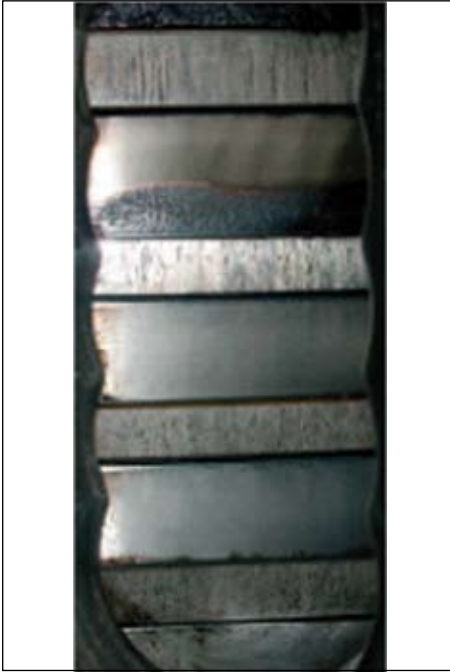

Fig. 8.25: Totally scuffed unit. Lubrication should be increased to maximum until overhaul is convenient with regard to the schedule of the ship. Due to the friction heat developed, the piston rings get hardened and the wear rate of the liner increases significantly. However, the hardening protects the rings, which is why operation may be continued safely until next convenient port stay.

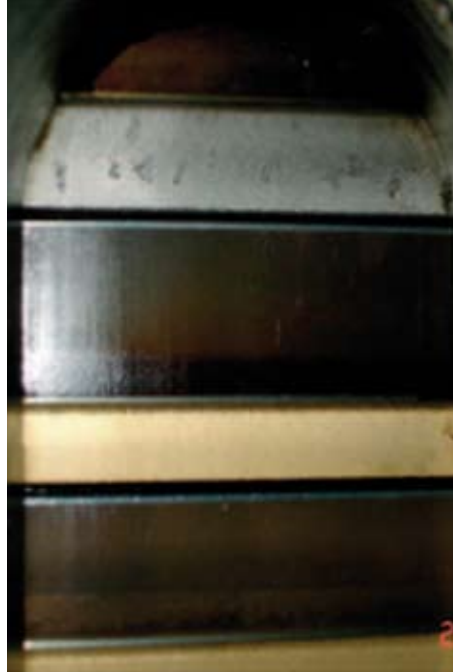

Fig. 8.26: Unit with micro-seizures on the top ring as a result of metal-to-metal contact. Should be counteracted by temporarily increased lubrication. It is important to lower the lubrication to normal as soon as the active mz-attack is stopped. Note that old, not active, mz-marks remain visible long after the attack has stopped and do not call for increased lubrication.



Fig. 8.27: Unit with 23,500 hours without piston overhaul. Note that most of the rounding is still intact, indicating that only 1/4 of the wear potential is used. Further, the measurements above from the same unit show that only 1/2 of the ring groove wear potential is used, and the rate of burnings on the piston top is insignificant. Consequently, overhaul of that unit is not needed at this stage.



Fig. 8.28: Totally scuffed unit. Lubrication should be increased to maximum until overhaul is convenient with regard to the schedule of the ship. Due to the friction heat developed, the piston rings get hardened and the wear rate of the liner increases significantly. However, the hardening protects the rings, which is why operation may be continued safely until next convenient port stay.



Fig. 8.29: Unit with micro-seizures on the top and bottom rings as a result of metal-to-metal contact. Should be counteracted by temporarily increased lubrication. It is important to lower the lubrication to normal as soon as the active mz-attack is stopped. Note that old, not active, mz-marks remain visible for a long time and do not call for increased lubrication.



Fig. 8.30: Unit running very well after 20,021 running hours. Note that the last remains of the alu-coat are still visible on the lower edge, indicating remaining rounding left. This means that the ring wear is less than 2 mm out of possible 3 mm. Consequently, many more hours are left from the point of view of wear.

CBO of exhaust valves

For the exhaust valve, the use of W-seat, Fig. 8.31, and either nimonic valve spindle or DuraSpindle has improved the overhaul intervals to longer than 32,000 hours. Fig. 8.32 shows examples of an excellent condition without overhaul with combinations of a W-seat/nimonic spindle and a W-seat/DuraSpindle achieved on an S60MC engine after 25,500 hours and 33,900 hours, respectively.

For exhaust valve stem seal, the so-called controlled oil Level (COL) design, Fig. 8.33, indicates that also stem seal overhaul intervals can be extended to

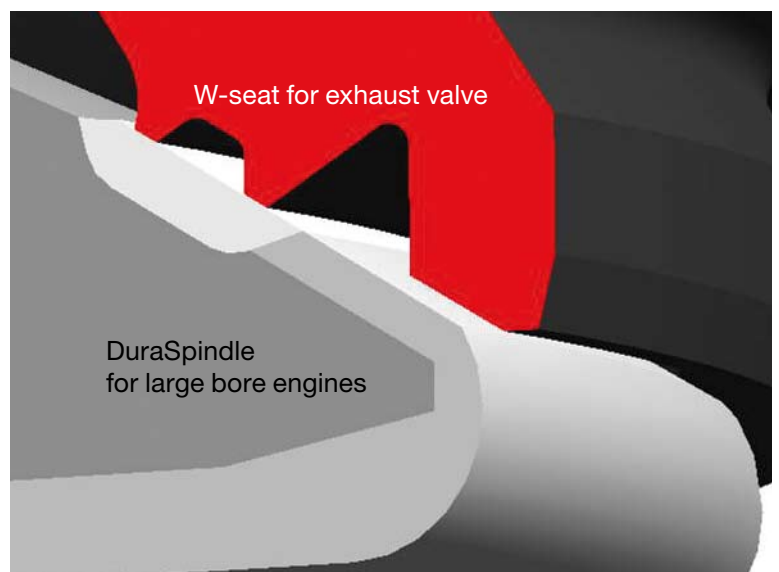

Fig. 8.31: W-seat and DuraSpindle combination

30,000-35,000 hours, based on results from several test units on 98, 90 and 60 bore engines. This illustrated by Fig. 8.34 showing an open-up inspection on a K98.

CBO of bearings

Since the late 1990s, a positive development with respect to main bearing damage has been seen. Despite the heavy increase in the number of main bearings on MC/MC-C engines, Fig. 8.35, the reported damage frequency remains very low, see Fig. 8.36.

For other bearing types (crosshead and crankpin bearings), the damage frequency is also very low.

However, in a few cases we experienced severe damage causing long-term off-hire periods involving also costly repairs of the bedplate and/or the crankshaft. An example is shown in Fig. 8.37. In this case, the reason for the damage was incorrect assembly after an open-up inspection of a main bearing after sea trial. This sequence of events following open-up inspections of bearings is unfortunately being reported from time to time. We have therefore changed our instruction material, not calling for open-up inspection at regular intervals. In parallel, we have made so-called bearing wear monitoring (BWM) systems a standard on engines ordered in 2008. BWM systems can also be retrofitted on existing engines

In principle, the BWM system monitors all the major bearings (main, crankpin and crosshead) by measuring the distance to the bottom dead centre of the crosshead, Fig. 8.38. The distance will decrease if wear occurs in one of the major bearings, and the BWM system can then give an alarm.



Fig. 8.32: W-seat in combination with nimonic spindle and DuraSpindle

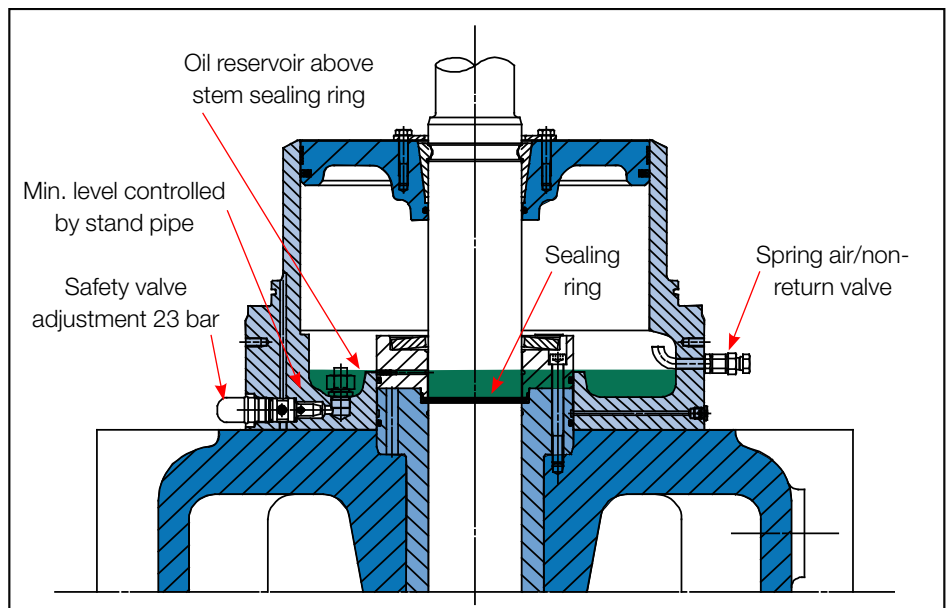
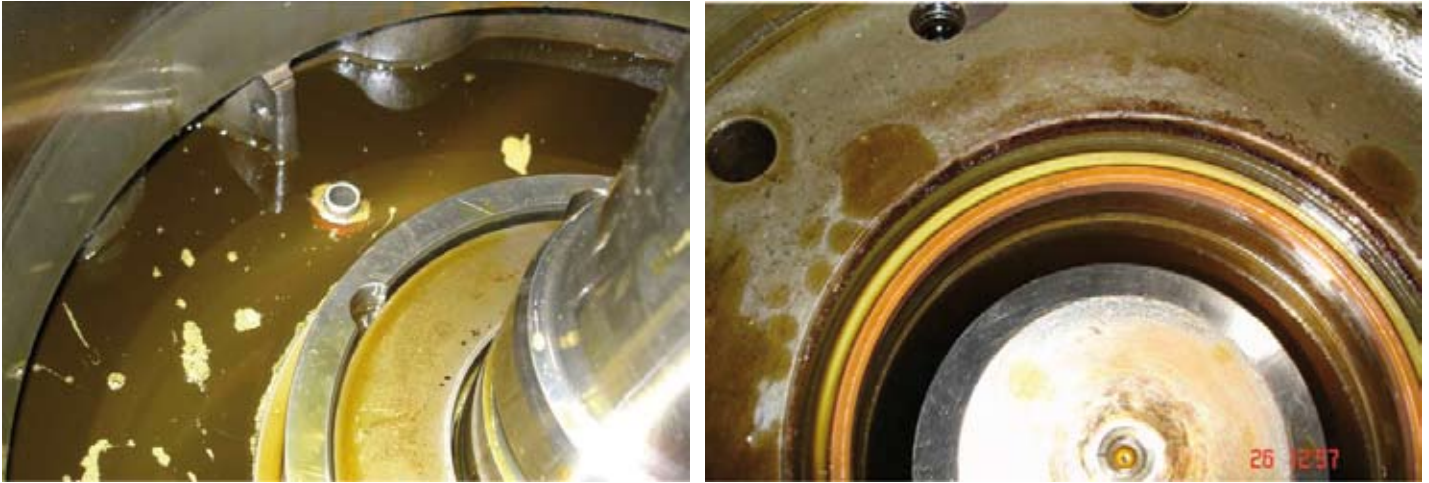

Fig. 8.33: Controlled oil level (COL) design



7K98MC: COL test unit, inspection after running hours 20,468 hours

Clean lubricated spindle guide and a sealing ring with a wear profile which well indicate running up to 30,000-35,000 hours



Fig. 8.34: Inspection of COL design

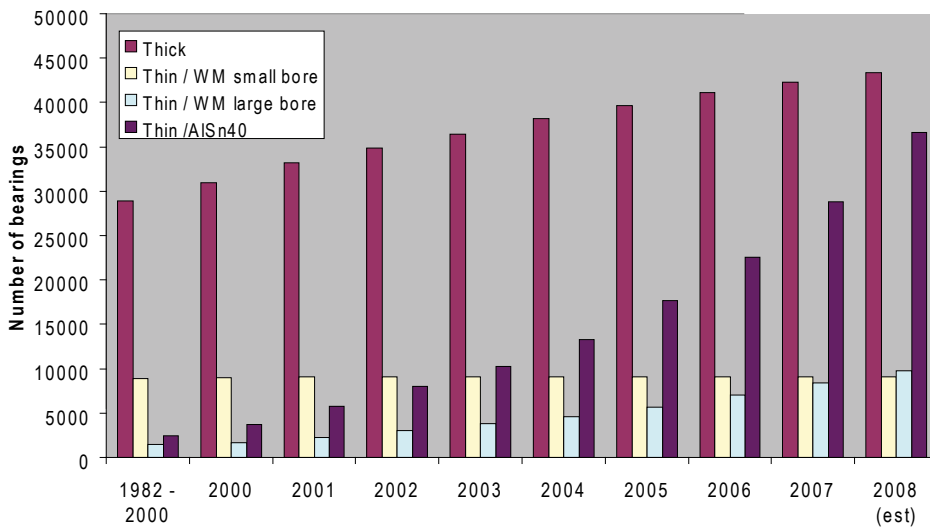

Fig. 8.35: Main bearing population 1982-2008 divided into bearing types

By monitoring wear in the major bearings, condition based monitoring (CBO) of bearings is introduced, and regular open-up inspections can be limited to fewer than previously. Optimally, open-up inspections should, if at all needed, only be carried out during dry-dockings or when indications (bearing metal in bedplate or BWM alarm) call for it.

This revised strategy will further limit the cases of severe bearing break-downs.

Also water in oil (WIO) monitoring systems have been added to the standard instrumentation for newly ordered engines. This is especially important

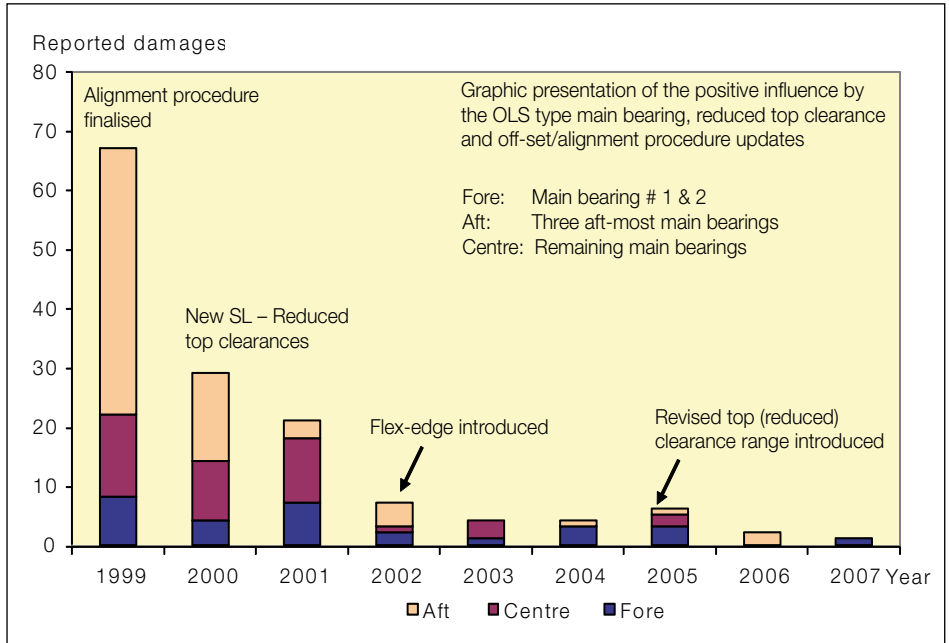
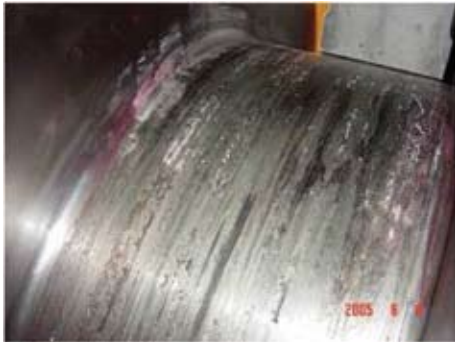

Fig. 8.36: Thick shell main bearing damage statistic

in relation to crosshead bearings with lead overlay being sensitive towards corrosion due to a too high water content in the system oil. For engines in service, WIO is described in service letter SL05-460.

Time between overhaul (TBO) for turbochargers

For turbochargers, the major makers are now promoting extended times between major overhauls (Fig. 8.39). This means that for new turbochargers, it will be realistic to require major overhauls only during docking of the vessel. The overhaul intervals will then in many cases be five years.



- 6S70MC-C on maiden voyage
- Continued running for 1½ hrs after 1st alarm
 - Main bearing incorrectly assembled after inspection
 - 3½ month repair

Fig. 8.37: Main bearing damage on 6S70MC-C

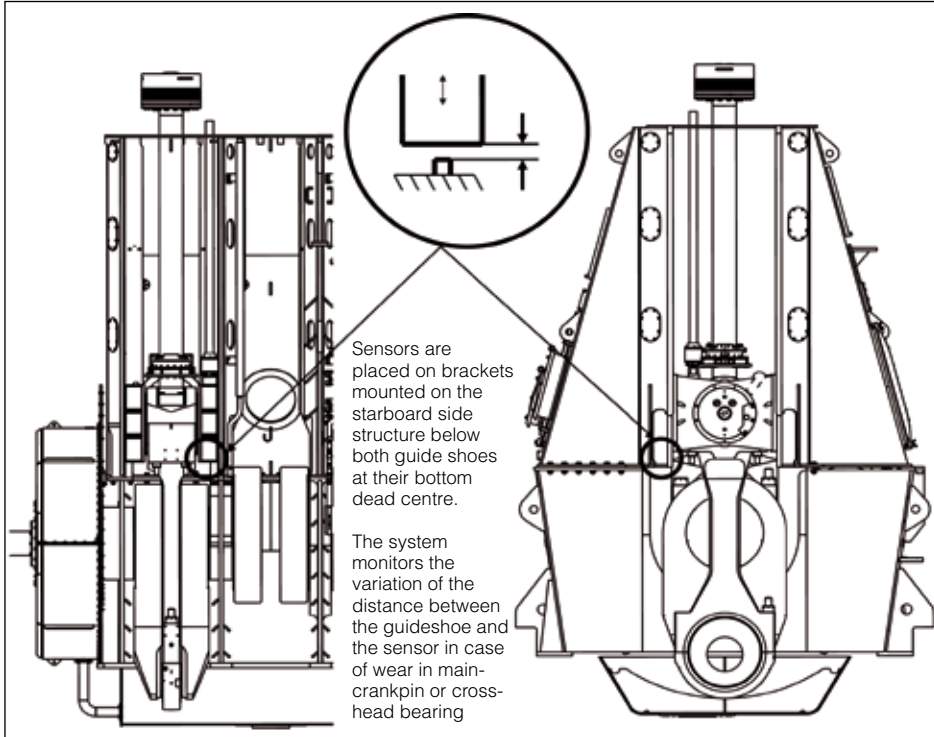

Fig. 8.38: Bearing Wear Monitoring (BWM), position of sensors



Fig. 8.39: Modern turbocharger enabling more than 30,000 hours between major overhauls

Conclusion

In 2007, we solved and concluded several service-related issues for the ME/ME-C engine series. Naturally, this work continues in 2008, and the main focus is still to make the updates in service without disturbing the operation of the vessels. This was possible in most cases in 2007, and we are confident that this will also be the case in future.

A condition based overhaul (CBO) strategy is ready for ME/ME-C and MC/MC-C engines. This means that in many cases overhaul intervals of 32,000 hours or even longer can be obtained.

For dry-cargo ship, container vessels and bulk carriers, a CBO strategy would mean much extended overhaul intervals, also in many cases exceeding 32,000 hours.

For tankers, the ideal overhaul strategy is to operate from dry-docking to dry-docking without major overhauls. It can be concluded from the above that this will be possible in the majority of the cases.