



MAN B&W Diesel

Key Components, Tegholmen Works



MC fuel pump

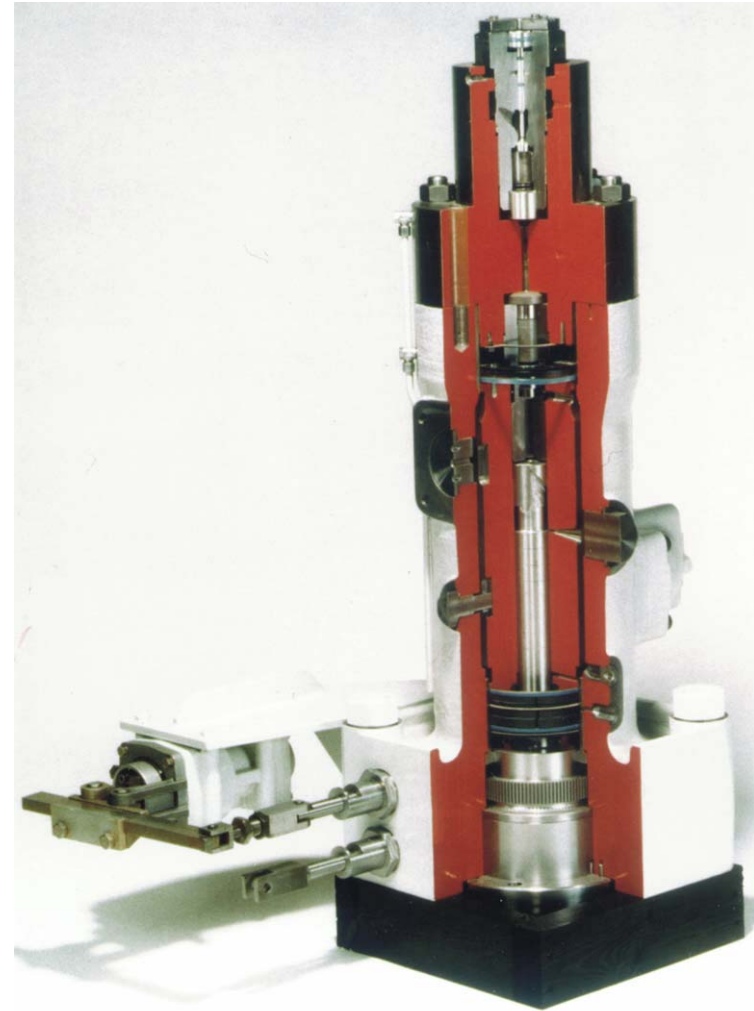
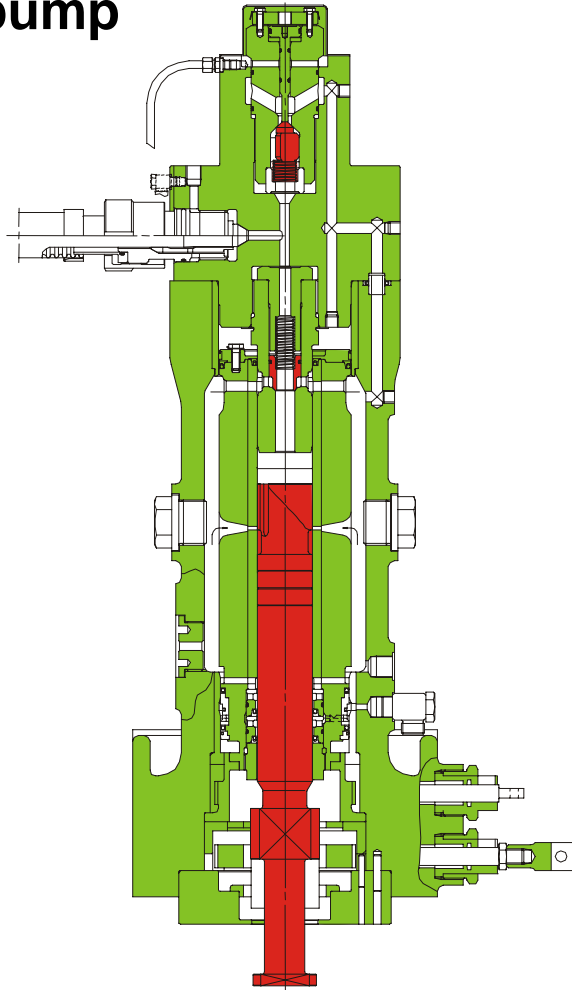



Fuel pump with 'umbrella' sealing

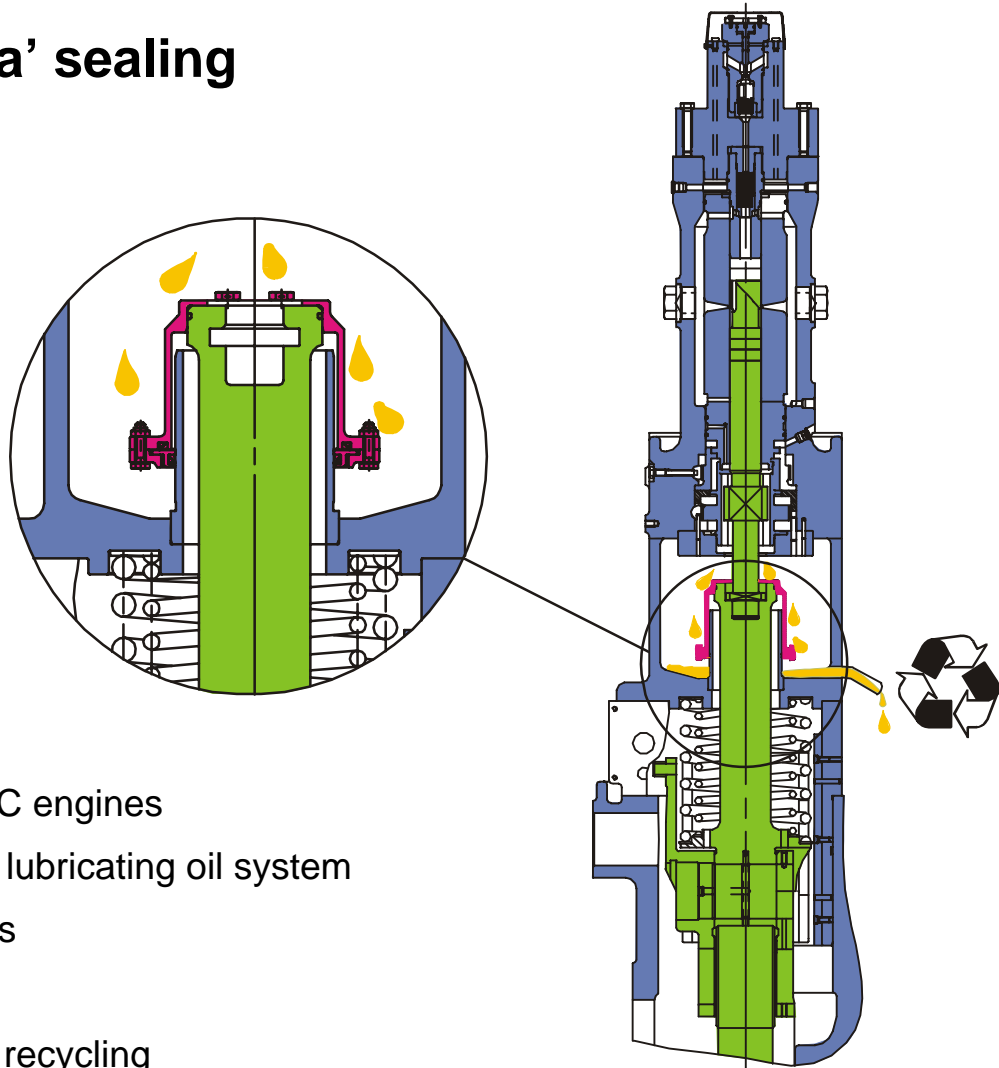

- Standard design on MC engines
- No separate camshaft lubricating oil system
- Lower installation costs
- Less maintenance
- Clean drain fuel oil for recycling



Fuel Pump Top Cover Fractures



S70MC/MC-C, 60MC/MC-C, S50MC/MC-C, S46MC-C, LS35MC

Previous

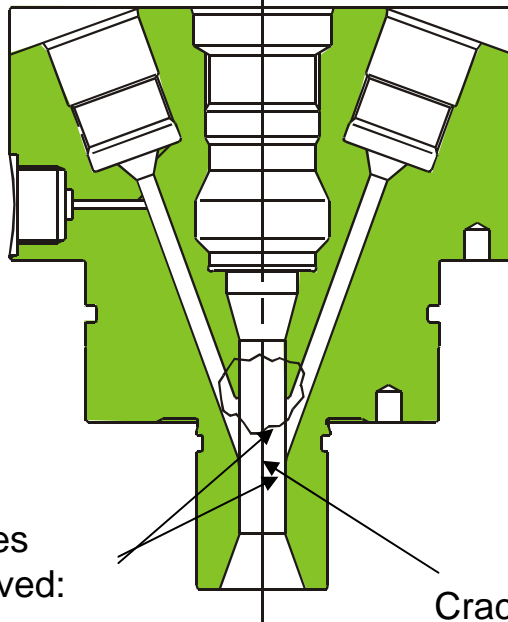

New

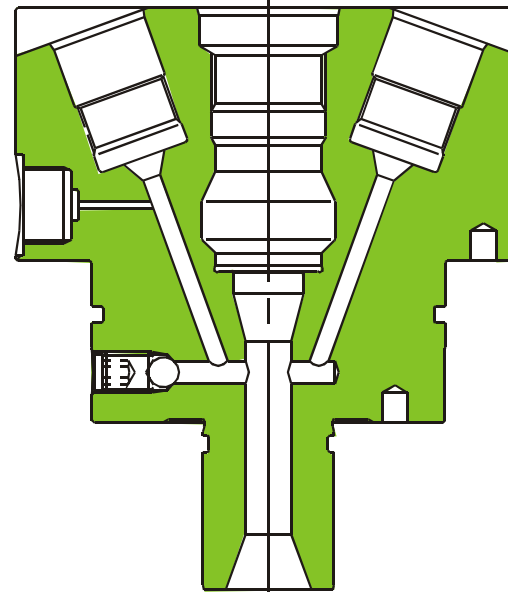

Sharp edges
to be removed:
R1-R10

Crack initiation area

SL02-412

The fractures have been experienced on small and medium bore engines. The fractures were initiated at the position where the inclined drillings for the high-pressure pipes intersect with the central bore. The cause of the failure has in all cases been related to roundings which did not fulfill our specifications.



Service Letter

SL02-412/NIM
December 2002

Fuel Pump Top Cover
L/S35MC, S46-50-60-70MC-C
(Fuel pumps without VIT)
Action Code: AT FIRST OPPORTUNITY

Dear Sirs

Since the introduction of the S-MC-C engines in 1997, a few cracks have been experienced on fuel pump top covers. The cases experienced indicate that such incidents occur, if at all, rather early in the engine lifetime.

The cracks are initiated at the edge between the central bore and the inclined bores, due to the lack of the specified manual finishing of the transition edge between the central bore and the inclined bore. The crack-initiated area is shown in Fig. 1.

We have noted that, in each case, the crack has developed into the bore for the suction valve, whereby high-pressure fuel is pumped into the low-pressure chamber. This reduces the fuel injection pressure, and the alarm for low exhaust gas temperature will be sounded so that the crew has the possibility of correcting the failure. We have not received any reports of cracks developing in such a way that fuel leaks out into the engine room.

Our investigation has shown that the safety margin against the development of cracks is sufficient, provided the specified manual finishing of the transition between the central bore and the inclined high-pressure bore has been carried out.

In order to eliminate the need for manual finishing during production, and as an alternative to this, we have introduced a modified design for future top covers. The design is shown in Fig. 2.

The modification involves the introduction of a horizontal bore connecting the vertical central bore and the inclined bores.

We recommend checking whether the spare cover is of the original design. If this is the case, please check the transition between the vertical bore and the inclined bores. The transition area must have a radius of min. 0.5 mm. On the spare top cover, the sharp edge must be removed and a rounding of min 0.5 mm must be made.

We consider that removing the sharp edge, as described, will rectify the cover, thus we recommend that you keep two spare covers on board.

In the event of any doubt about the execution of the top cover, please contact the engine supplier for clarification.

Questions or comments regarding this SL should be directed to our Dept. 2300.

Yours faithfully

MAN B&W Diesel A/S

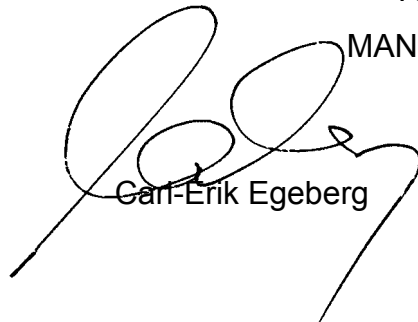

Carl-Erik Egeberg

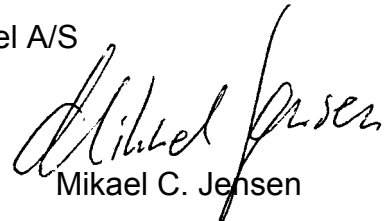

Mikael C. Jensen

Encl.

Fuel Pump Top Cover

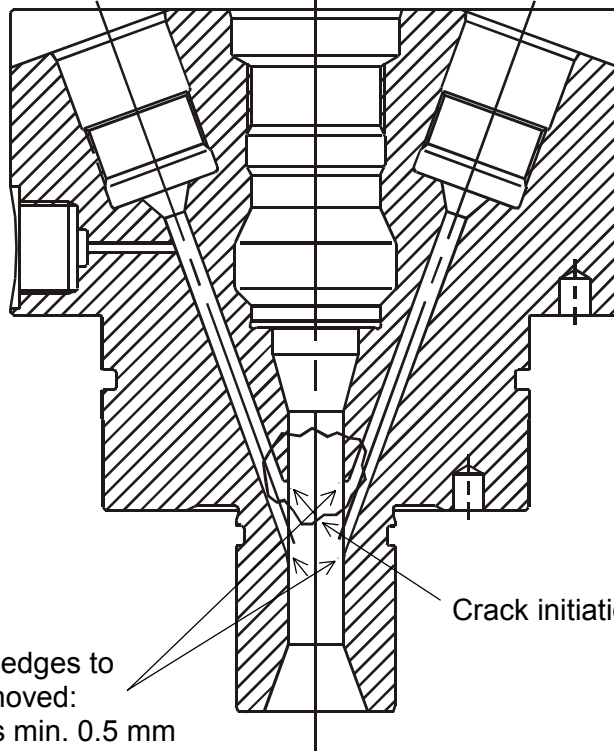

*Fig. 1:
Previous design*

Sharp edges to
be removed:
Radius min. 0.5 mm

Crack initiation area

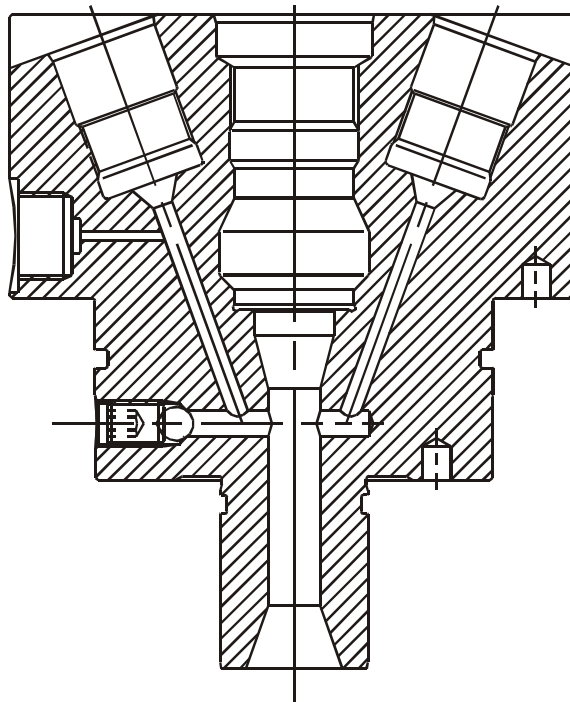

*Fig. 2:
Modified design*



Fuel Pump



Features:

- One shock absorber per pump
- Suction and puncture valves
- VIT adjustment

Improvements:

- Four-hole plunger barrel design
- Two-chamber design on K98MC, K98MC-C and S90MC-C

Verification

- Extensive calculations of pressure fluctuations
- Has been tested in a test rig

Puncture valve

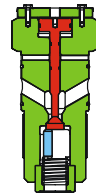

90-50 cm bore engines

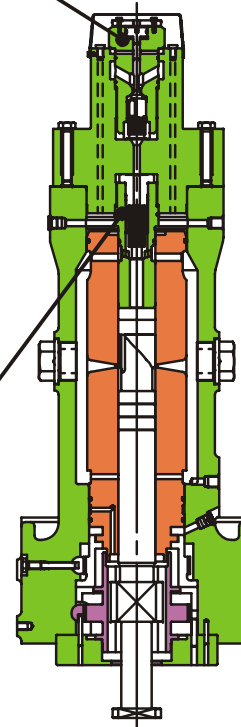

Combined suction and puncture valve

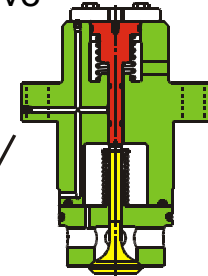

K98MC
K98MC-C
S90MC-C

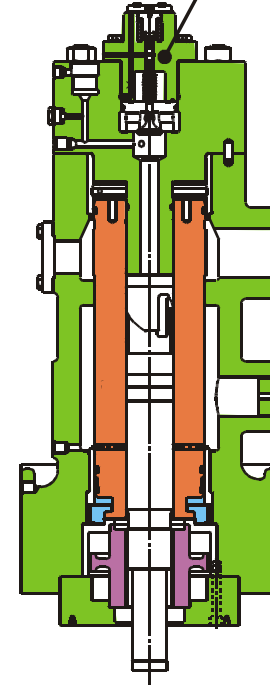

Suction valve





MAN B&W Diesel

Fuel pump suction and puncture valve combined

70MC/MC-C, 60MC/MC-C, 50MC/MC-C, 46MC/MC-C



Due to cracked bellows, the design has been changed.

Unit item 2 from modified design is interchangeable with unit item 2 from previous design.

98MC/C-C, 90MC/C-C, 80MC/C-C only without bellows.

Comb. puncture and suction valve for engines w/o VIT system

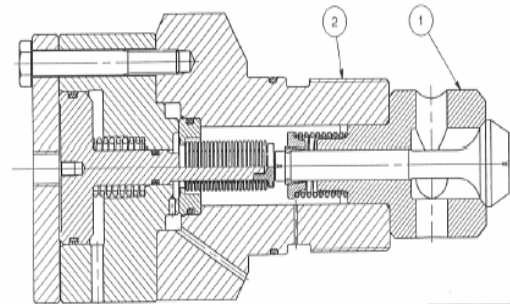

Previous design with bellows

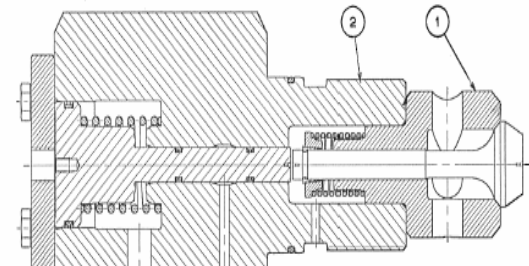

Modified design w/o bellows



Fuel Pump Suction Valve



50-90MC/MC-C

Expected lifetime 40,000 hours

Modified according to SL97-344

Slide without groove and sealing ring and with reduced clearance.

And where the slide again has been modified with a chamfering to ensure proper functioning irrespective of the fuel quality.

MBD-C Produced Valves

Always ensure to use the latest design.

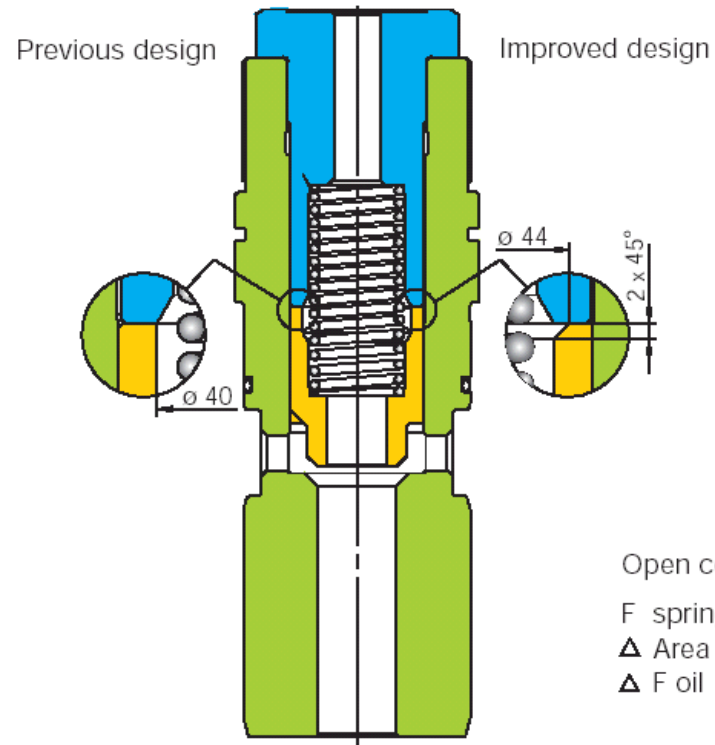

Open condition:

$F_{\text{spring}} = 156 \text{ N}$

$\Delta \text{Area} = 264 \text{ mm}^2$

$\Delta F_{\text{oil}} = 185 \text{ N}$



Service Letter

SL97-344/RØL
February 1997

Fuel Pump Suction Valve
50-90MC/MC-C Engines
Sealing Ring on Slide

Dear Sirs,

We have recently experienced incidents in which damage has occurred to the sealing ring on the fuel pump suction valve slide.

As a damaged sealing ring might lead to malfunctioning of the suction valve, we have made investigations and tests on suction valves without a sealing ring.

The results of these tests revealed that the suction valve can operate satisfactorily without the sealing ring, and we therefore recommend that the sealing ring be removed at the next suction valve overhaul.

It is preferable to remove the sealing rings on all suction valves at the same time, as the fuel index will be slightly affected.

As for future spare parts deliveries, this suction valve slide will be specified without the sealing ring groove, and with a slightly reduced clearance between the slide and the valve housing, please see Enclosure 1.

Yours faithfully,

MAN B&W Diesel A/S

Encl.

HEAD OFFICE (& Postal address)
Teglhølmegade 41
DK-2450 Copenhagen SV
Telephone: +45 33 85 11 00
Telex: 16592 manbw dk
Telefax: +45 33 85 10 30
E-mail: manbw@manbw.dk
<http://www.manbw.dk>

DIESEL SERVICE
Teglhølmegade 41
DK-2450 Copenhagen SV
Telephone: +45 33 85 11 00
Telex: 31197 manbw dk
Telefax: +45 33 85 10 49
E-mail: diesel-service@manbw.dk

PRODUCTION
Teglhølmegade 35
DK-2450 Copenhagen SV
Telephone: +45 33 85 11 00
Telex: 19023 manfw dk
Telefax: 19042 manfw dk
Telefax: +45 33 85 10 17
E-mail: manufacturing/copenhagen@manbw.dk

FORWARDING
Teglhølmegade 35
DK-2450 Copenhagen SV
Telephone: +45 33 85 11 00
Telex: 19023 manfw dk
Telex: 19042 manfw dk
Telefax: +45 33 85 10 16

MAN B&W Diesel A/S
Denmark
Reg.No.: 24 231

ENCLOSURE 1

ORIGINAL SUCTION VALVE
FOR Mk 3 & 5 FUEL PUMP
WITHOUT UMBRELLA

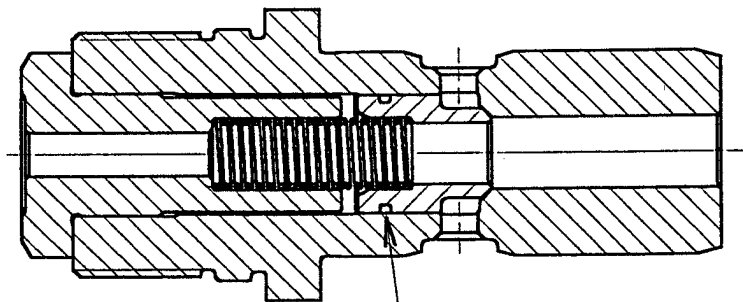

SEALING RING TO BE REMOVED
ON ENGINES IN SERVICE

NEW SUCTION VALVE
FOR Mk 3 & 5 FUEL PUMP
WITHOUT UMBRELLA

SPARE PART

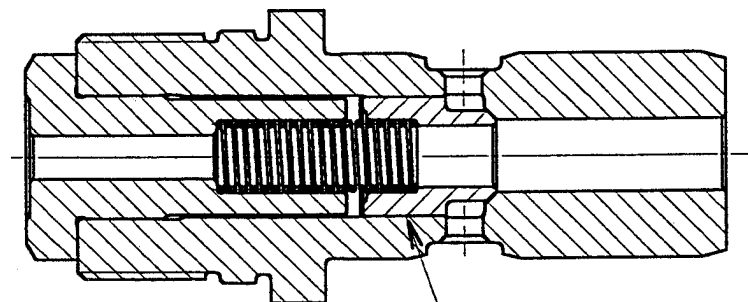

SLIDE WITHOUT GROOVE
AND WITH REDUCED CLEARANCE



New development will be built into your spares

Fuel pump suction valve

- Interchangeable
- Instructions to engine room staff

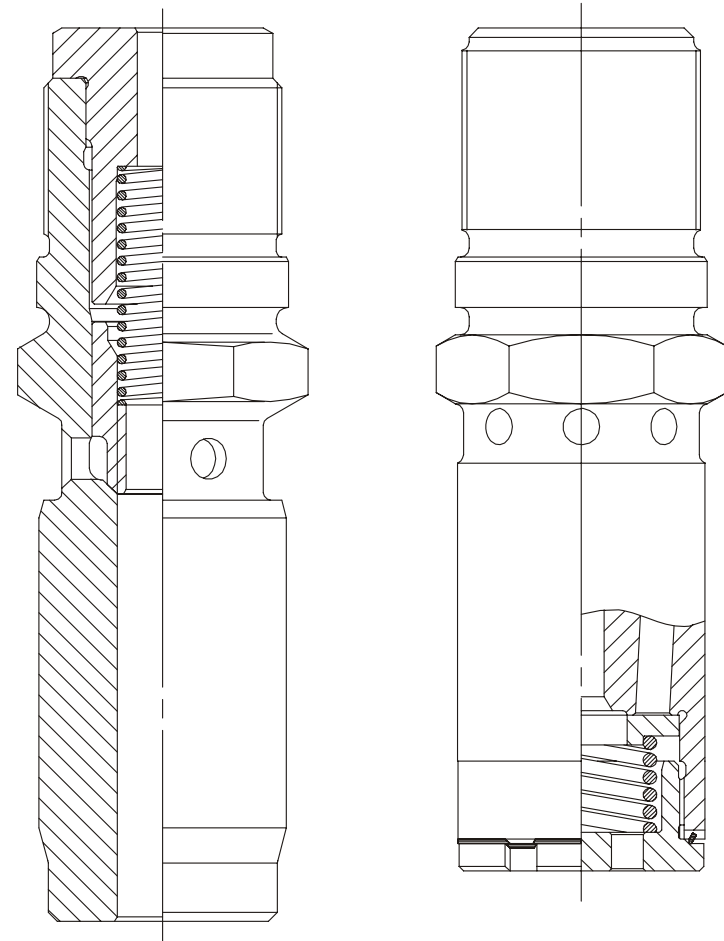



Fuel pump housing 98MC/MC-C, 90MC/MC-C



S90-K98MC/MC-C

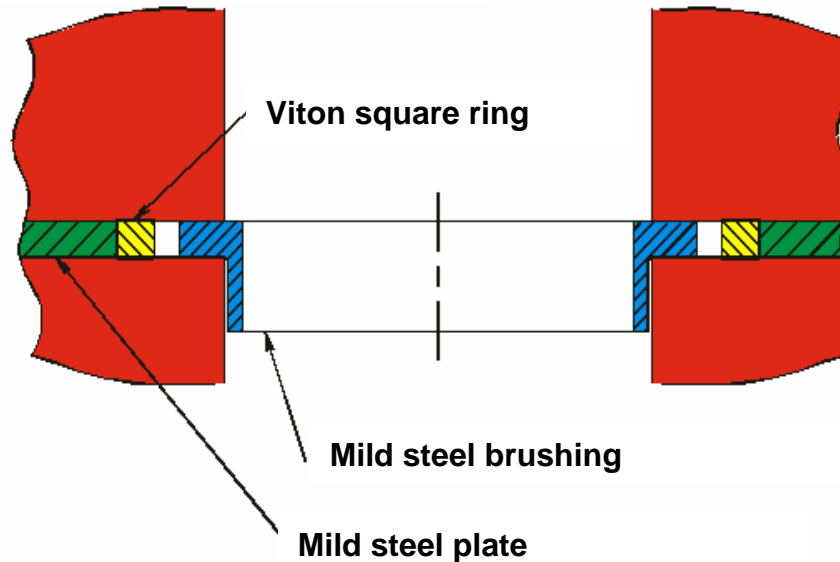

The previous fibre packing has been modified and is fully interchangeable with the above mentioned unit.

Afterwards only Viton square ring has to be changed.



MAN B&W Diesel

Fuel Pump Roller Guide – 'Umbrella'

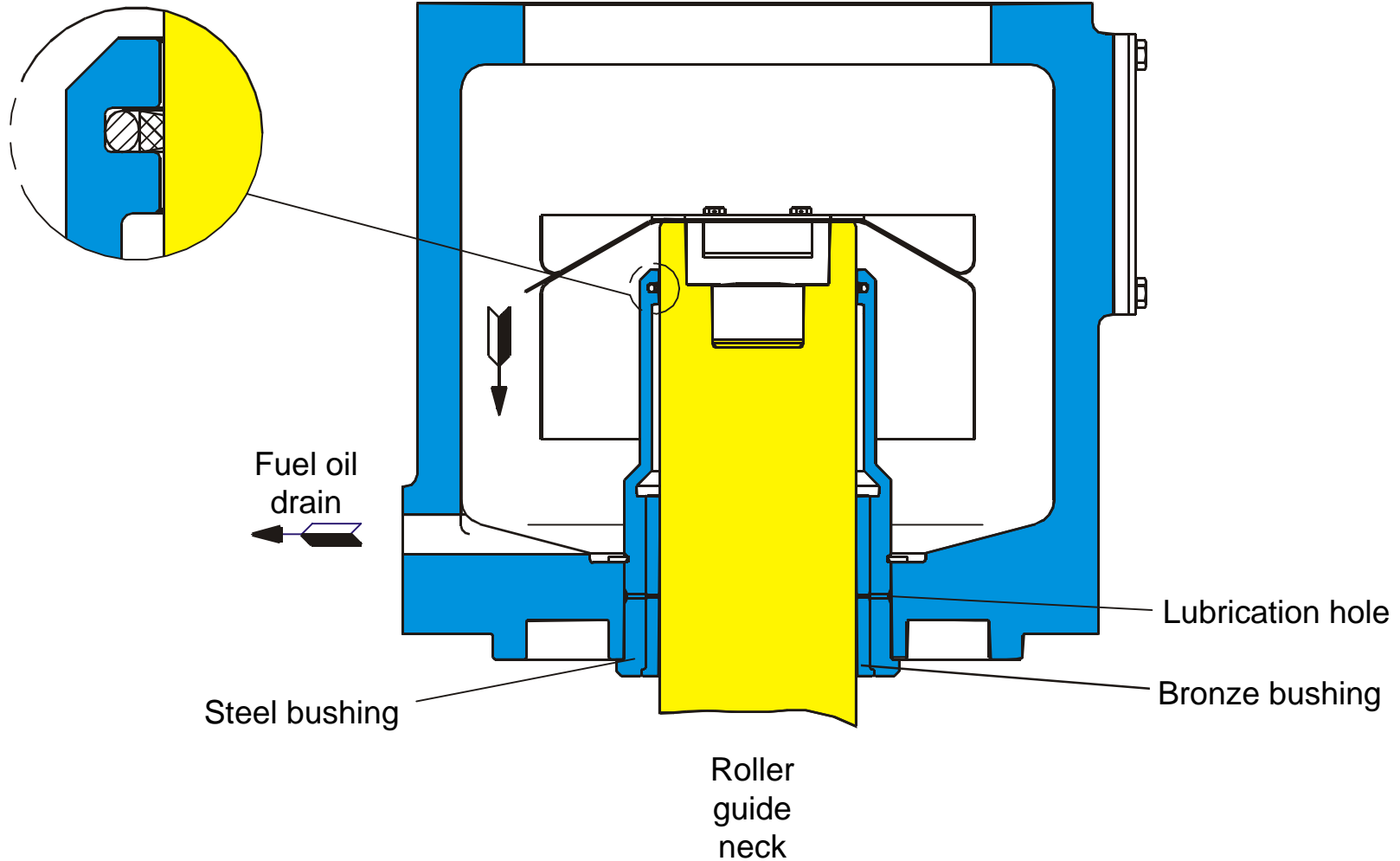



'Umbrella' roller guide for fuel pump (K98MC-C and K98MC engines)

Previous design

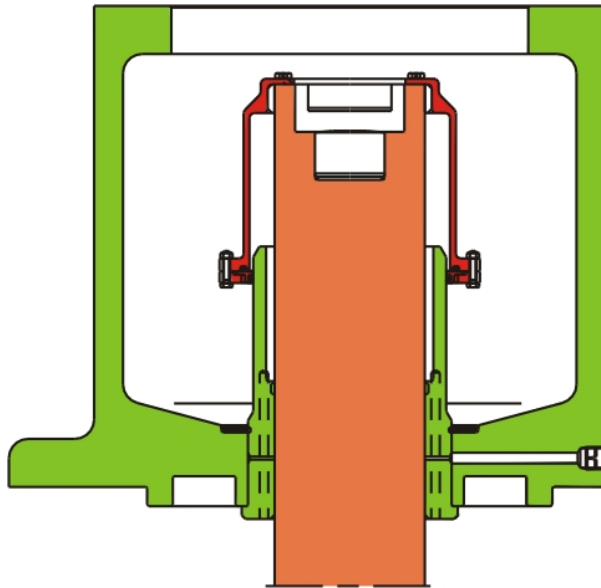

New design

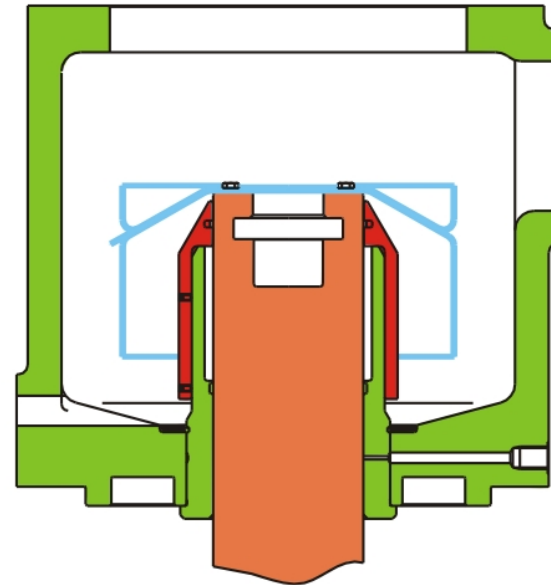



Fuel Pump



50-90 cm bore MC and MCE engines K/L45-55-67-80-80GB/GF/GFC/GFCA

In a few cases cracks have appeared in the sealing ring groove of the housing

In certain cases the guide ring acts as a tight sealing ring because the high running temperature reduces the ring gap to almost nothing

A pressure of approx. ten times the normal working pressure is then built up, hence causing the cracks

The problem was solved by exchanging the guide ring with a new ring with larger gap

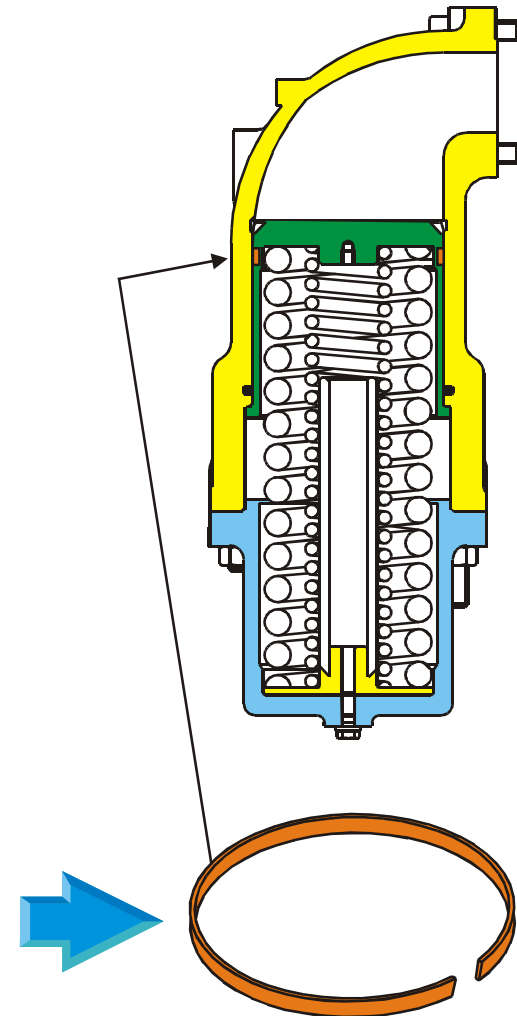



Reversing link for fuel pump roller guide

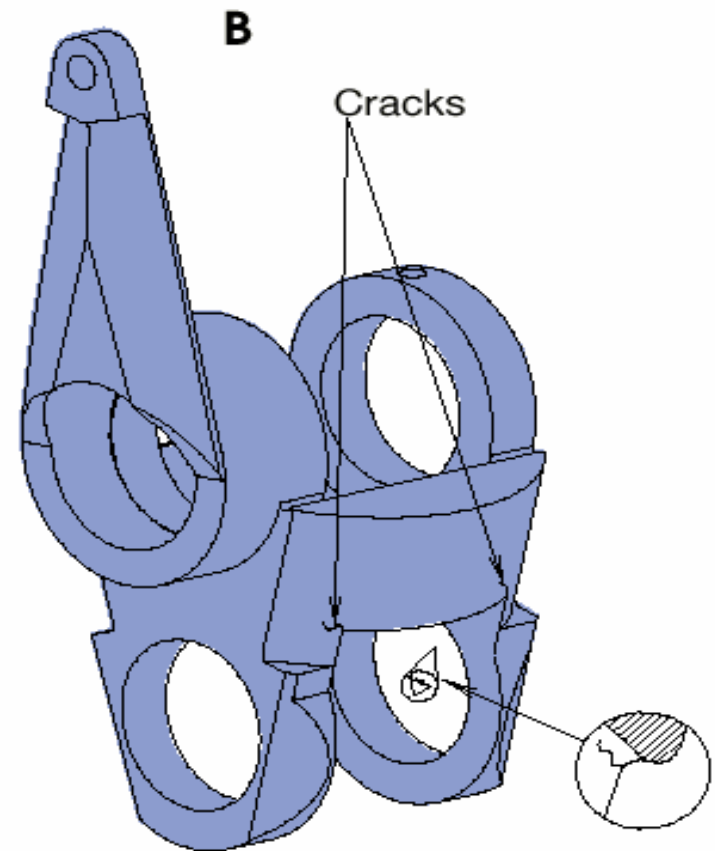
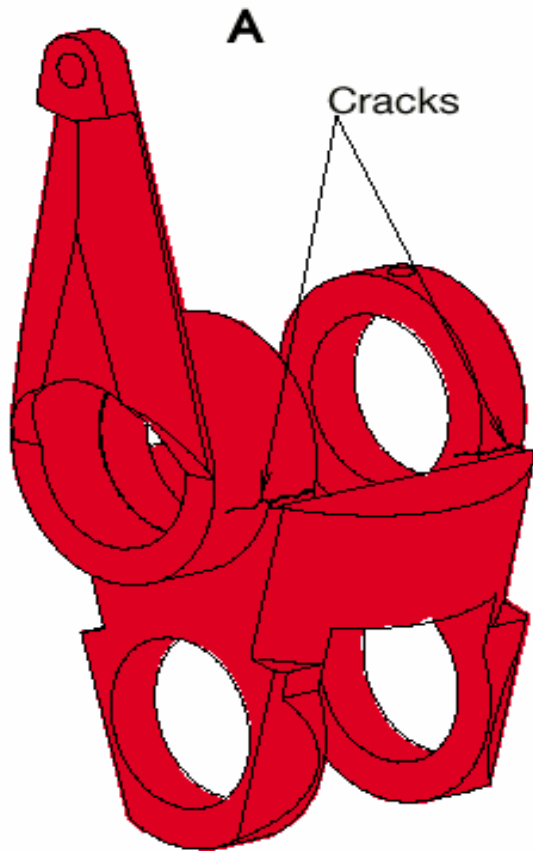

SL97-345



Service Letter

SL97-345/UM
March 1997

MC Engines
Reversing Link for Fuel Pump Roller Guide

Dear Sirs,

We have recently received reports on cracks in the reversing link for the fuel pump roller guide. The sketch in Enclosure 1 shows the appearance of the cracks.

The cracks as shown in Fig. B have mainly been found on the K90MC/MC-C types, Mark V or VI, and they were found after a relatively short time in service. The type of cracks indicated in Fig. A have only been reported in a few cases.

The cracks in Fig. B have primarily been located on the camshaft side and can be detected through the inspection cover in the camshaft housing. We recommend that, as a general precaution, you instruct your crews to inspect the reversing link at the first opportunity.

Even if no cracks as shown in Fig. B are detected, it is still recommended to inspect for the types of cracks shown in Fig. A, when convenient. It is necessary to pull out the roller guide in order to do this.

If cracks are detected, we ask you to make a sketch of the extent of the cracks and forward it to the engine builder or MAN B&W Diesel, Copenhagen and, at the same time, to order replacement reversing links. The new reversing links are modified with larger roundings in the relevant areas.

HEAD OFFICE (& Postal address)
Teglhølmegade 41
DK-2450 Copenhagen SV
Telephone: +45 33 85 11 00
Telex: 16592 manbw dk
Telefax: +45 33 85 10 30
E-mail: manbw@manbw.dk
<http://www.manbw.dk>

DIESEL SERVICE
Teglhølmegade 41
DK-2450 Copenhagen SV
Telephone: +45 33 85 11 00
Telex: 31197 manbw dk
Telefax: +45 33 85 10 49
E-mail: diesel-service@manbw.dk

PRODUCTION
Teglhølmegade 35
DK-2450 Copenhagen SV
Telephone: +45 33 85 11 00
Telex: 19023 manfw dk
Telex: 19042 manfw dk
Telefax: +45 33 85 10 17
E-mail: manufacturing/copenhagen@manbw.dk

FORWARDING
Teglhølmegade 35
DK-2450 Copenhagen SV
Telephone: +45 33 85 11 00
Telex: 19023 manfw dk
Telex: 19042 manfw dk
Telefax: +45 33 85 10 16

MAN B&W Diesel A/S
Denmark
Reg.No.: 24 231

If a reversing link has not shifted to its correct position after a change of the engine rotation, and fuel injection takes place, this running condition leads to increased stresses in the areas where cracks have been detected.

If such a running condition is repeatedly detected in your vessel, we recommend that you contact the engine builder or MAN B&W Diesel, Copenhagen, for a condition check of the complete manoeuvring system.

Furthermore, we want to draw your attention to another subject which should be considered in connection with the above recommended inspection of the reversing links. We have received a few reports regarding loose guide blocks for the fuel pump roller guide, see Enclosure 2. Therefore, when checking for cracks in the reversing link, we recommend that also the guide blocks are checked at the same time to see whether they are loose. This can be done when pulling the roller guide.

For 70-80 and 90 MC engines, another method is to make the check through the inspection opening as stated in the procedure in Enclosure 3.

To improve the fixing of the guide blocks, it must be ensured that the guide pins are inserted in the holes with a tight fit. Furthermore, when new screws are mounted, these should be tightened to the torque indicated in Encl. 2, and locked with Loctite. The new screws should not be locked by caulking, as hitting the screw head improperly, could lead to a reduction of the tightening force of the screw.

It is necessary to order new screws from the engine builder or MAN B&W Diesel beforehand in order to make sure that correct screws are used.

Yours faithfully,

MAN B&W Diesel A/S

Two handwritten signatures in black ink. The signature on the left is a stylized, cursive name. The signature on the right is also cursive and appears to be a different name or a more formal signature.

Encl.

Reversing Link for Fuel Pump Roller Guide

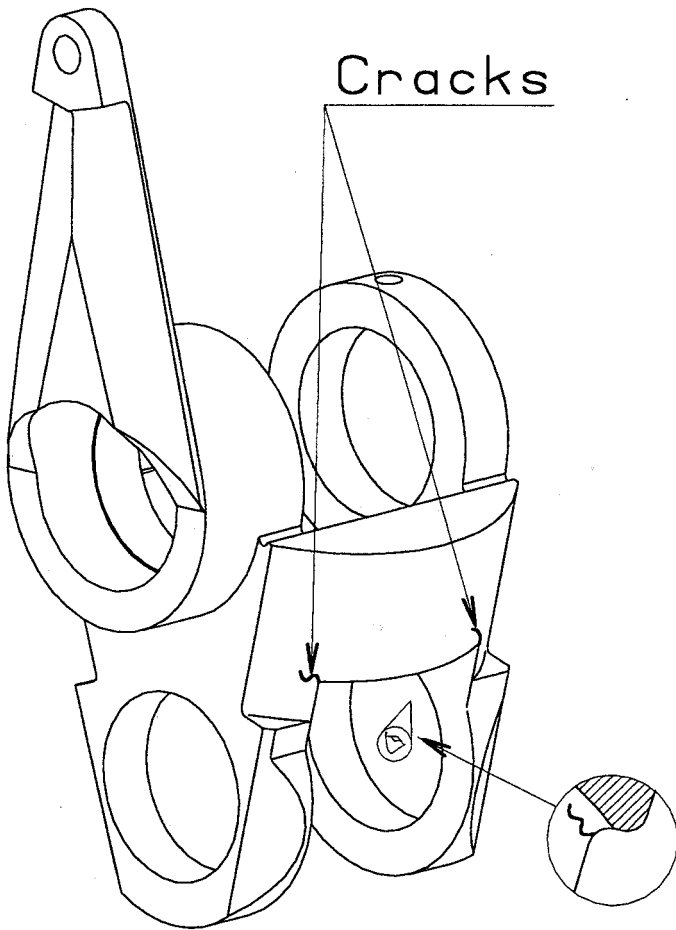

Figure B

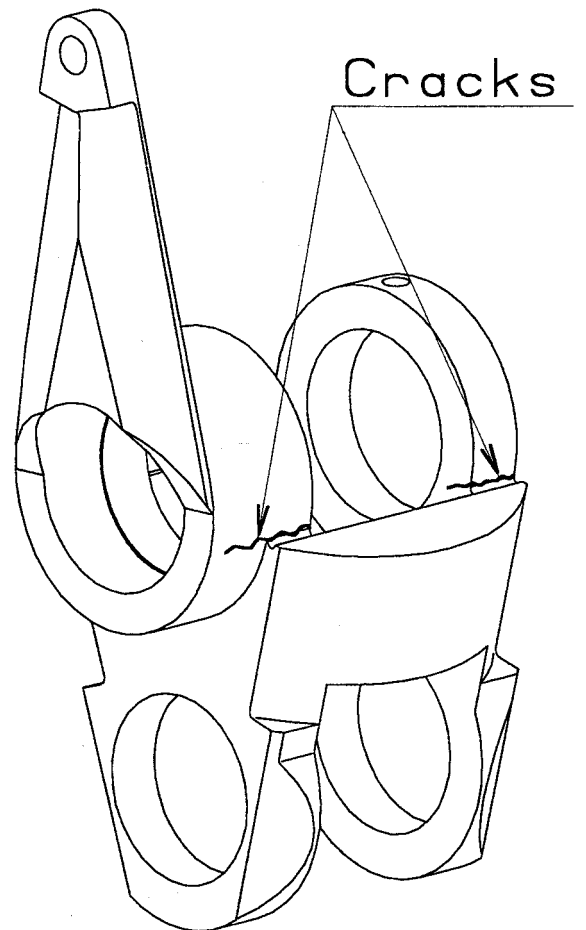
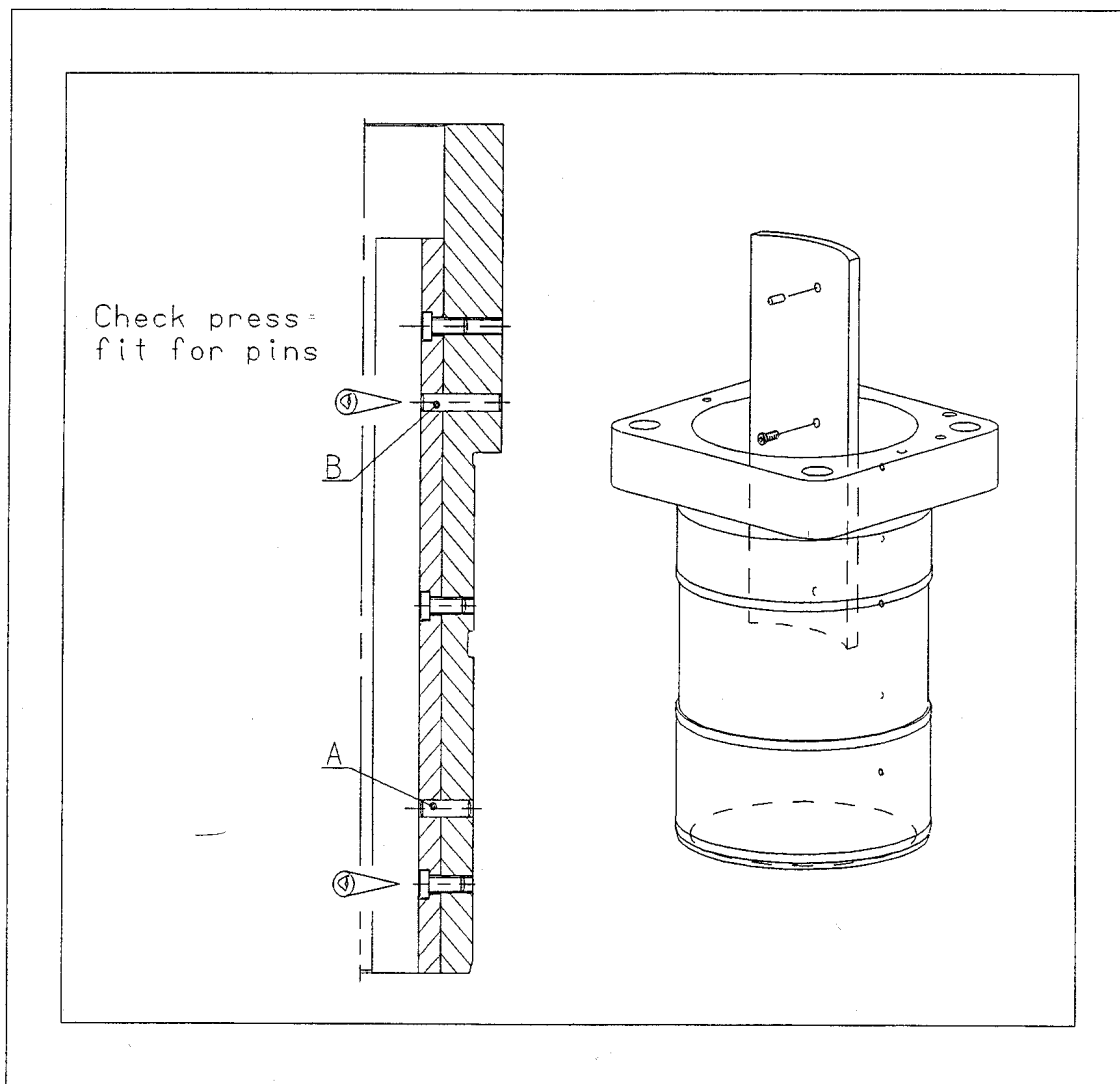

Figure A



Engine type	Tight. torque Nm		Screw size hex.sock.low head cap screw	Pin size A Diam. x length	Pin size B Diam. x length
S 26		7	M6 x 16	6 x 20	6 x 32
S/L 35	L	7	M6 x 12	6 x 12	6 x 32
	S	7	M6 x 10	6 x 24	6 x 24
S/L 42	L	7	M6 x 12	6 x 18	6 x 28
	S	7	M6 x 16	6 x 18	6 x 28
S/L 50	Fuel	7	M6 x 20	6 x 24	6 x 36
	Exh.	7	M6 x 12	6 x 16	6 x 16
S/L 60		17	M8 x 16	8 x 20	8 x 45
S/L 70		17	M8 x 25	8 x 32	8 x 50
S/K/L 80		35	M10 x 30	10 x 36	10 x 40
S/K/L 90		60	M12 x 30	12 x 40	12 x 60

S/K/L--MC(-C)

Checking and changing screws at fuel pump guide block

Checking:

The tightness of the guide block can be checked without dismantling the fuel pump. This is done by opening the inspection cover for the fuel cam on the camshaft housing, and turning the engine so as to position the roller assembly in "Astern", and at its highest position.

With the roller assembly in this position, it is possible to reach the lowest of the three screws which secure the guide block to the liner. The tightness of the screw can be tried with an Allen key after ascertaining that the size of key is correct for the particular engine.

For safety reasons, it is very important, when checking for loose screws through the inspection covers, that the links do not change position. This is secured by disconnecting the air supply from both sides of the reversing air cylinders.

- Our experience indicates that, if the lowermost screw is tight, the two other screws are also tight, and the guide block is considered in order.
- However, if the lowermost screw is loose, the pump must be lifted and the below procedure must be applied for mounting the new screws.

Mounting of special screws in fuel pump guide block:

1. Dismantle the old screws.
2. Check that the dowel pins are not damaged. If they are damaged, re-check the alignment of the guide block.
3. Check that it is possible for the new screw to seat properly in the old hole in the guide block.
4. Mount the new screws after soaking their threads with Loctite 222. **Note:** It is necessary to degrease the threads.
5. Mount the screws, starting with the lowermost screw.
6. After tightening the top screw, retighten all the screws to the specified torque.
7. Tightening torque: *See enclosed table, Enclosure 2.*

Note: The guide block must not be caulked after tightening.