

# **PARTS CATALOG**

**EXCAVATOR  
R110-7**

*Use the bookmarks for navigation inside the Parts book*

Tech. Library <https://engine.od.ua>

# **HYUNDAI**

## Excavator R110-7

Page	Contents	Serial_No	Revision_No
<b>1</b>	<b>ENGINE SYSTEM</b>		
1010	ENGINE MOUNTING		2010. 6.30 REV.10F
1020	ENGINE CONTROL SYSTEM		2009. 4.22 REV.9D
1030	AIR INTAKE SYSTEM		2006.12.31 REV.6M
1040	EXHAUST SYSTEM		2005.11.30 REV.5L
1050	COOLING SYSTEM		
1060	RADIATOR ASSY		
1070	FUEL SYSTEM		2009. 9. 1 REV.9J
1080	FUEL TANK		2009. 10.30 REV.9K
1090	AIRCON & HEATER MOUNTING		2010. 6.30 REV.10F
1100	AIRCON & HEATER UNIT(-#0223)	- #0223	2006. 4.30 REV.6D
1101	AIRCON & HEATER UNIT(#0224-)	#0224 -	2010. 6.30 REV.10F
1110	AIR CONDITIONER MOUNTING		2010. 6.30 REV.10F
1120	AIR CONDITIONER UNIT		2010. 6.30 REV.10F
1130	HEATER MOUNTING		2007.10.31 REV.7K
1140	HEATER UNIT(-#0223)	- #0223	2006. 4.30 REV.6D
1141	HEATER UNIT(#0224-)	#0224 -	2006. 4.30 REV.6D
1160	AIRCON & HEATER MOUNTING(AUTO)		2010. 6.30 REV.10F
1170	AIRCON & HEATER UNIT-FATC		2010. 6.30 REV.10F
<b>2</b>	<b>ELECTRIC SYSTEM</b>		
2010	RH ELECTRIC		2009. 8.31 REV.9H
2020	LH ELECTRIC		2007. 3.31 REV.7C
2030	BOOM ELECTRIC		
2040	ENGINE ELECTRIC		2009. 8.31 REV.9H
2050	ELECTRIC BOX		2009. 8.17 REV.9H
2060	CAB ELECTRIC 1		2010. 2.28 REV.10B
2070	CAB ELECTRIC 2		2010. 2.28 REV.10B
2080	CAB ELECTRIC 3		2008. 6.30 REV.8F
2085	ELEC CAB LAMP SUB ASSY(OPTION)	#0395 -	2008. 6.30 REV.8F
2090	FUEL FILLER PUMP		2008. 6.30 REV.8F
2100	FUSE BOX		
2110	CLUSTER		
2120	CLUSTER(UPGRADE)	#0458 -	2008. 6.30 REV.8F
<b>3</b>	<b>HYDRAULIC SYSTEM</b>		
3010	PUMP MOUNTING		2007. 4.30 REV.7D
3020	HYDRAULIC TANK		2009. 3.31 REV.9C
3030	UPPER HYDRAULIC PIPING(BASE)		2007. 4.30 REV.7D
3040	UPPER HYDRAULIC PIPING(ATTACH)		
3050	UPPER HYDRAULIC PIPING(TRAVEL)		2010. 5.31 REV.10E
3060	PILOT HYDRAULIC PIPING(CONTROL 1)		2007. 3.31 REV.7C
3070	PILOT HYDRAULIC PIPING(CONTROL 2)		2009. 3.31 REV.9C
3080	PILOT HYDRAULIC PIPING(CONTROL 3)		2008. 3.31 REV.8C
3090	PILOT HYDRAULIC PIPING(BASE 1)		
3100	PILOT HYDRAULIC PIPING(BASE 2)		
3110	PILOT HYDRAULIC PIPING(BASE 3)		
3200	TRAVEL HYDRAULIC PIPING(STD)		2009. 8.25 REV.9H
3300	TRAVEL HYD PIPING(DOZER BLADE 1)		2009. 8.25 REV.9H
3350	TRAVEL HYD PIPING(DOZER BLADE 2)		
3400	BOOM HYDRAULIC PIPING(4.3M, STD)		
3410	BOOM GREASE LUB SYSTEM(4.3M, STD)		2008. 3.31 REV.8C
3500	BOOM SAFETY LOCK SYSTEM		2008. 6.30 REV.8F
3600	ARM HYDRAULIC PIPING		2005. 8.31 REV.5H
3610	ARM SAFETY LOCK SYSTEM		2008. 6.30 REV.8F
3700	DOZER BLADE HYDRAULIC PIPING(UPPER)		
3800	QUICK CLAMP HYD PIPING		2006. 6.30 REV.6F
3900	DOUBLE ACTING MAIN PIPING KIT		2005. 2.28 REV.5B
3910	D/ACT MAIN PIPING KIT(DOZER)		2005. 2.28 REV.5B
3920	SINGLE ACTING MAIN PIPING KIT		2005. 2.28 REV.5B
3930	DOUBLE ACTING ATTACH PIPING KIT		2005. 2.28 REV.5B

<b>4</b>	<b>HYDRAULIC COMPONENT</b>		
4010	MAIN PUMP		
4020	REGULATOR		2008. 3.31 REV.8C
4030	GEAR PUMP		
4040	MAIN CONTROL VALVE(1/4)		2005.10.31 REV.5K
4050	MAIN CONTROL VALVE(2/4)		2009. 5.31 REV.9E
4060	MAIN CONTROL VALVE(3/4)		
4070	MAIN CONTROL VALVE(4/4)		2009. 5.31 REV.9E
4080	SWING MOTOR		2007. 4.30 REV.7D
4090	SWING REDUCTION GEAR		2007. 4.30 REV.7D
4100	TRAVEL MOTOR(1/2, TYPE 1)		2009. 8.25 REV.9H
4110	TRAVEL MOTOR(2/2, TYPE 1)		2009. 8.25 REV.9H
4120	TRAVEL REDUCTION GEAR(TYPE 1)		2009. 8.25 REV.9H
4130	TRAVEL MOTOR(1/2, TYPE 2, #0535-)	#0535 -	2009. 8.25 REV.9H
4131	TRAVEL MOTOR(2/2, TYPE 2, #0535-)	#0535 -	2009. 8.25 REV.9H
4135	TRAVEL REDUCTION GEAR(TYPE 2, #0535-)	#0535 -	2009. 8.25 REV.9H
4140	REMOTE CONTROL LEVER		2009. 6.30 REV.9F
4145	REMOTE CONTROL LEVER(OPT, #0381)		2007. 8.31 REV.7H
4150	REMOTE CONTROL PEDAL		
4160	TURNING JOINT		
4170	TURNING JOINT(R110D-7, DOZER)		2005.11.30 REV.5L
4180	BOOM CYLINDER		
4190	ARM CYLINDER		2006.12.31 REV.6M
4200	BUCKET CYLINDER		
4210	DOZER BLADE CYLINDER		2008. 5.31 REV.8E
4220	SOLENOID VALVE		
4400	QUICK CLAMP ASSY		2006. 6.30 REV.6F
4420	QUICK CLAMP ASSY(#0252-)	#0252 -	2006. 4.30 REV.6D
4430	QUICK CLAMP ASSY 3(#0300-)	#0300 -	2006.11.30 REV.6L
4440	QUICK CLAMP ASSY 4(#0300-)	#0300 -	2006.11.30 REV.6L
4500	QUICK CLAMP CYLINDER(#0300-)	#0300 -	2006.11.30 REV.6L
<b>5</b>	<b>UNDERCARRIAGE</b>		
5010	UNDERCARRIAGE MOUNTING		2008.12.31 REV.8M
5020	LOWER ROLLER		2008.12.31 REV.8M
5030	UPPER ROLLER		2008. 12.31 REV.8M
5040	IDLER		2007. 4.30 REV.7D
5050	TRACK CHAIN		2010. 1. 4 REV.10A
5060	ADJUST COMPONENT		2008.12.31 REV.8M
<b>6</b>	<b>STRUCTURE</b>		
6010	CAB MOUNTING		2009. 12.10 REV.9M
6020	CAB ASSY(1/6, STD & FOG TYPE)		2009.12.30 REV.9M
6021	CAB ASSY(1/6, STD & FOG, #0458-)	#0458 -	2009.12.30 REV.9M
6025	CAB ASSY(1/6, ROOF TYPE)		2009.12.30 REV.9M
6026	CAB ASSY(1/6, ROOF TYPE, #0458-)	#0458 -	2009.12.30 REV.9M
6030	CAB ASSY(2/6)		
6031	CAB ASSY(2/6, #0485-)	#0485 -	2008. 11.30 REV.8L
6035	CAB ASSY(2/6, #0458-)	#0458 -	2008. 4.30 REV.8D
6040	CAB ASSY(3/6)		2008. 6.30 REV.8F
6045	CAB ASSY(3/6, OPT, #0458-)	#0458 -	2008. 6.30 REV.8F
6050	CAB ASSY(4/6, DOOR)		2008. 4.30 REV.8D
6060	CAB ASSY(5/6, SASH ASSY)		
6070	CAB ASSY(6/6, DOOR LATCH ASSY)		
6080	CAB INTERIOR 1		
6085	CAB INTERIOR 2		2008. 4.30 REV.8D
6090	CAB INTERIOR 1(OPT, #0458-)	#0458 -	2008. 4.30 REV.8D
6095	CAB INTERIOR 2(OPT, #0458-)	#0458 -	2008. 4.30 REV.8D
6100	CONSOLE BOX(1/2, LH)		
6105	CONSOLE BOX(1/2, LH, OPT, #0458-)	#0458 -	2008. 4.30 REV.8D
6110	CONSOLE BOX(2/2, LH)		
6115	CONSOLE BOX(2/2, LH, OPT, #0458-)	#0458 -	2008. 4.30 REV.8D
6120	CONSOLE BOX(RH)		2006. 2.28 REV.6B
6125	CONSOLE BOX(RH, OPT, #0458-)	#0458 -	2008. 4.30 REV.8D

6130	SEAT BASE ASSY		2007.10.31 REV.7K
6140	SEAT(-#0037)		2005. 2.28 REV.5B
6141	SEAT(#0038-)		2005. 2.28 REV.5B
6145	SEAT 2 (#0012-)		
6146	SEAT 3 (#0315-)		2006. 9.30 REV.6J
6148	SEAT 4 (#0412-)	#0412 -	2008. 4.30 REV.8D
6150	STORAGE BOX COVER ASSY		
6160	BOTTOM PLATE MOUNTING		
6170	BOTTOM PLATE MOUNTING(OPT, #0458-)	#0458 -	2008. 4.30 REV.8D
6200	COWLING		2007.12.31 REV.7M
6210	SIDE COWL ASSY(LH)		2006. 7.31 REV.6G
6220	SIDE COVER ASSY(LH)		2006. 7.31 REV.6G
6230	SIDE COWL ASSY(RH)		2006. 7.31 REV.6G
6240	ENGINE HOOD ASSY		
6260	UNDER COVER		2009. 7.22 REV.9G
6270	TOOL BOX MOUNTING		2010. 2.28 REV.10B
6280	TOOL BOX		2007. 4.30 REV.7D
6290	CAB PROTECTOR ASSY(OPTION)	#0395 -	2008. 6.30 REV.8F
6300	UPPER FRAME & COUNTERWEIGHT		2010. 5.31 REV.10E
6310	GROMMET GROUP		2009. 3.31 REV.9C
6400	LOWER FRAME & COVER		2009. 7.22 REV.9G
6500	SWING RING GREASE LUB SYSTEM		2010. 7.31 REV.10G
6600	DOZER BLADE		2007. 4.30 REV.7D
<b>7</b>	<b>ATTACHMENT</b>		
7010	BOOM MOUNTING(4.3M, STD)		2009. 3.31 REV.9C
7100	BOOM(4.3M, STD)		2008. 3.31 REV.8C
7200	ARM(2.26M, STD)		
7210	ARM(1.96M)		
7220	ARM(2.81M)		
7300	BUCKET CONTROL GROUP		2010. 5.31 REV.10E
7400	BUCKET(0.45M3 SAE HEAPED, STD)		2008. 6.30 REV.8F
7410	BUCKET(0.30M3 SAE HEAPED)		2008. 6.30 REV.8F
7420	BUCKET(0.40M3 SAE HEAPED)		2008. 6.30 REV.8F
7430	BUCKET(0.50M3 SAE HEAPED)		2008. 6.30 REV.8F
7440	BUCKET(0.59M3 SAE HEAPED)		2008. 6.30 REV.8F
<b>8</b>	<b>OTHERS</b>		
8010	TOOLS		
8100	DECALS		2010. 5.31 REV.10E
<b>9</b>	<b>ENGINE BASE</b>		
9010	CYLINDER HEAD		
9020	VALVE MECHANISM		
9030	ROCKER COVER & BREATHER		
9040	CAMSHAFT		
9050	CRANKECASE ASSY		
9060	CRANKECASE		
9070	TIMING GEAR CASE 1		
9080	TIMING GEAR CASE 2		
9090	FLYWHEEL HOUSING		
9100	OIL PAN		
9110	PISTON & CONNECTING ROD		
9120	CRANKSHAFT & FLYWHEEL		
9130	TIMING GEAR		
9140	INLET & EXHAUST SYSTEM		
9150	TURBOCHARGER		
9160	OIL STRAINER		
9170	OIL PIPE		
9180	OIL COOLER		
9190	OIL FILTER		
9200	WATER PUMP		
9210	COOLING SYSTEM		
9220	FUEL SYSTEM		
9230	NOZZLE		2008. 4.29 REV.8D

9240	FUEL FILTER		
9250	ELECTRIC PARTS		
9260	STARTER		
9270	ALTERNATOR		
9280	CONTROL SYSTEM		
9290	OVERHAUL GASKET KIT		

# ENGINE CONTROL SYSTEM

ENGINE ASSY(9010~9290)

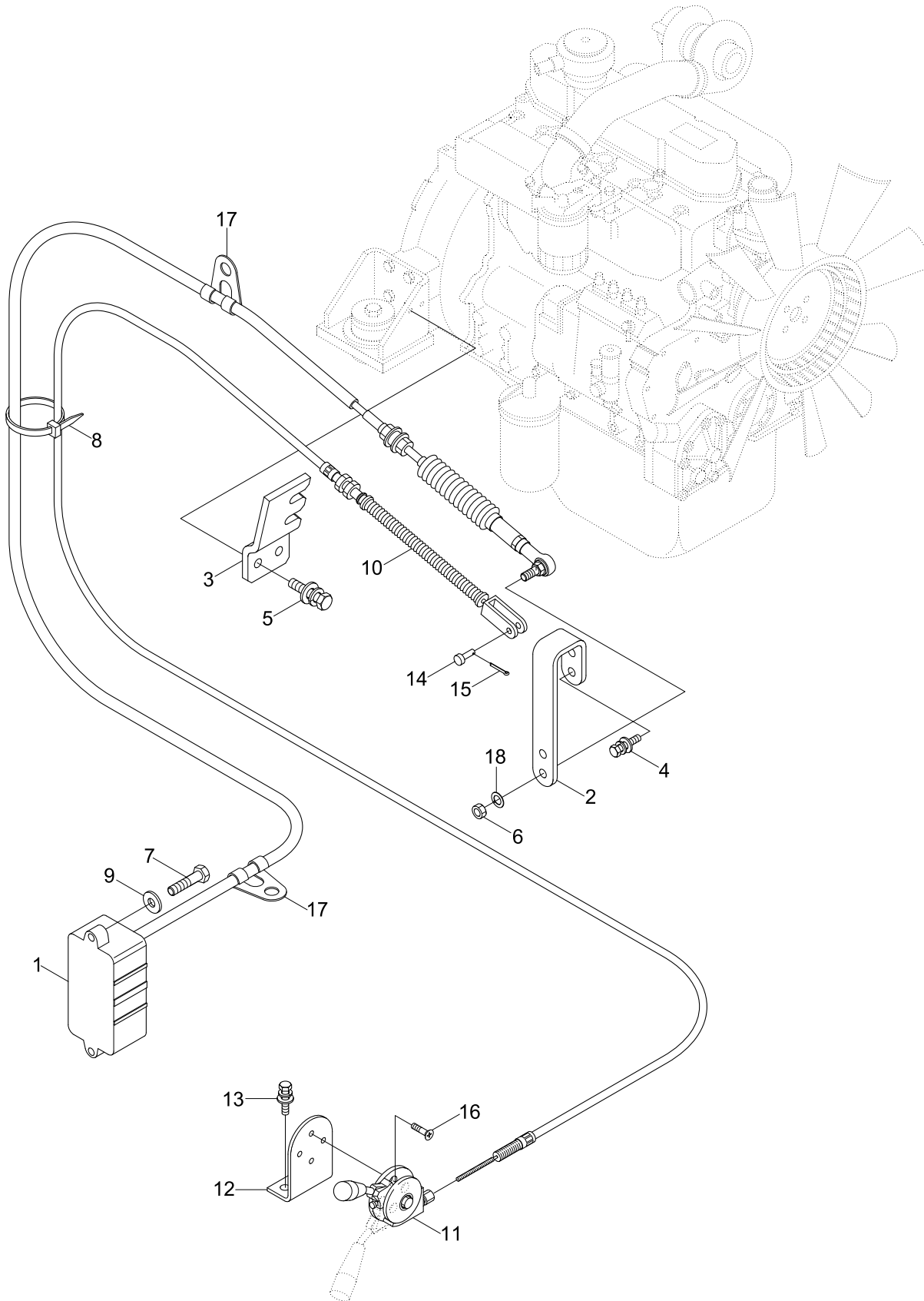

Item	Part_No	IS	Ord	T	Description	Qty	Serial_No	ITC	Remark
1	21EN-32260				ACCEL ACTUATOR	1			
2	11N3-60021				LEVER-SPEED	1			
3	11N3-60010				BRACKET-CABLE	1			
4	S035-062022				BOLT-W/WASHER	2			
5	S035-082022				BOLT-W/WASHER	2			
6	S205-08100B				NUT-HEX	1	- #0551		
	S275-08000B				NUT-SELF LOCKING	1	#0552 -	B	
7	S015-080352				BOLT-HEX	2			
8	S551-020102				CLAMP-BAND	4			
9	S403-082002				WASHER-PLAIN	2			
10	11N8-60171				CABLE-THROTTLE	1			
11	11N6-63041				LEVER-EMERGENCY	1			
12	11N6-63050				BRACKET	1			
13	S037-102522				BOLT-W/WASHER	2			
14	S491-060252				PIN-CLEVIS	1			
15	S461-160152				PIN-SPLIT	1			
16	S141-080142				SCREW-FLAT HD	4			
17	S593-000902				CLIP-HARNESS	2			
18	S411-080006				WASHER-SPRING	1	#0552 -	-	

# AIR INTAKE SYSTEM

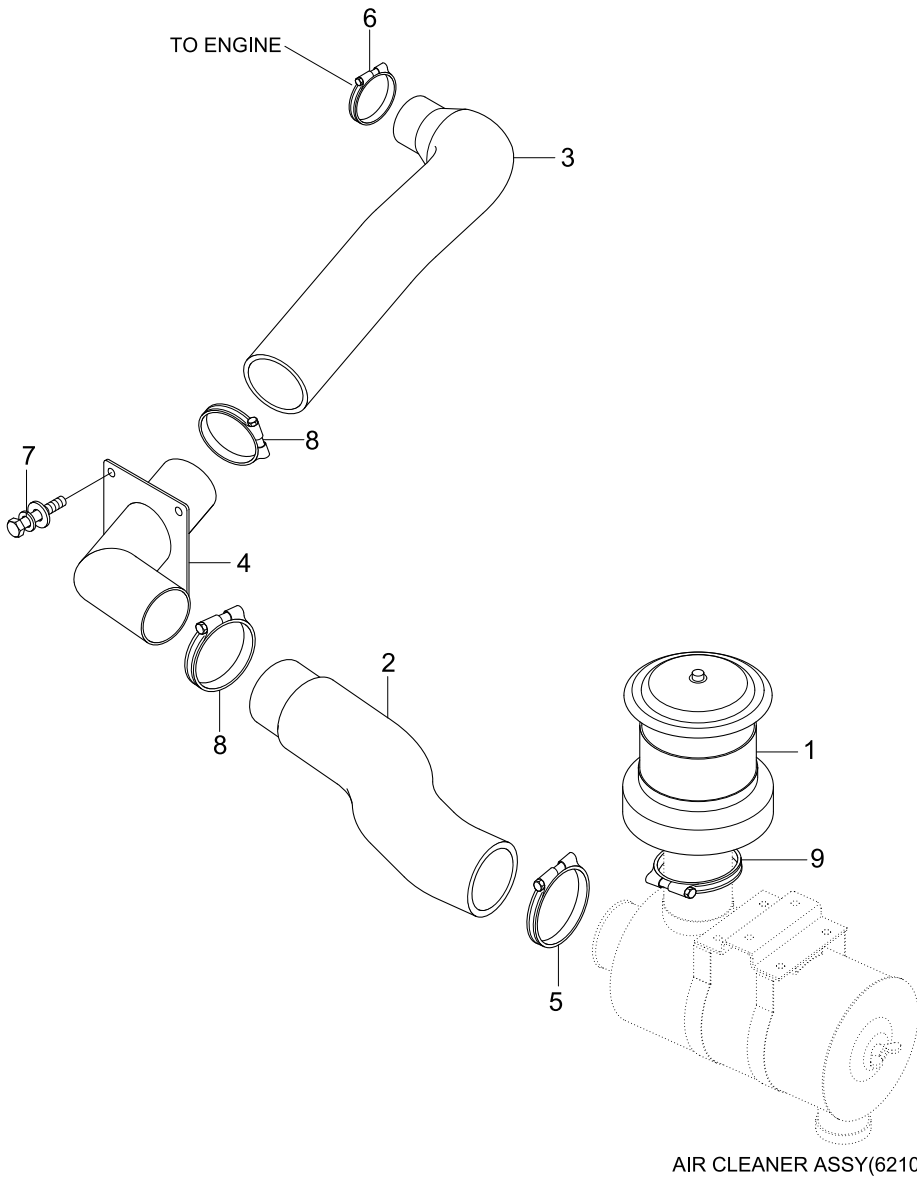



Item	Part_No	IS	Ord	T	Description	Qty	Serial_No	ITC	Remark
1	11N6-23060				PRECLEANER	1	- #0037		
	11N6-23061				PRECLEANER	1	#0038 -	B	
2	11N3-20021				HOSE-AIR CLEANER	1			
3	11N3-20041				HOSE	1			
4	11N3-20030				PIPE WA-A/C HOSE	1			
5	11E6-21240				CLAMP-HOSE	1	- #0192		
	11LB-40310				CLAMP-HOSE	1	#0193 -	B	
6	11N6-20230				CLAMP-T-BOLT	1	- #0457		
	11N6-20231				CLAMP-T-BOLT	1	#0458 -	B	
7	S035-082522				BOLT-W/WASHER	4			
8	11N6-20201				CLAMP-BAND,T-BOLT	2	- #0056		
	11N6-20350				CLAMP-T/BOLT	2	#0057 - #0192	B	
	11LB-40280				CLAMP-HOSE	2	#0193 -	A	
9	11LB-40180				CLAMP-HOSE	1	#0337 -	-	

# BOOM ELECTRIC

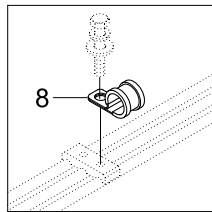
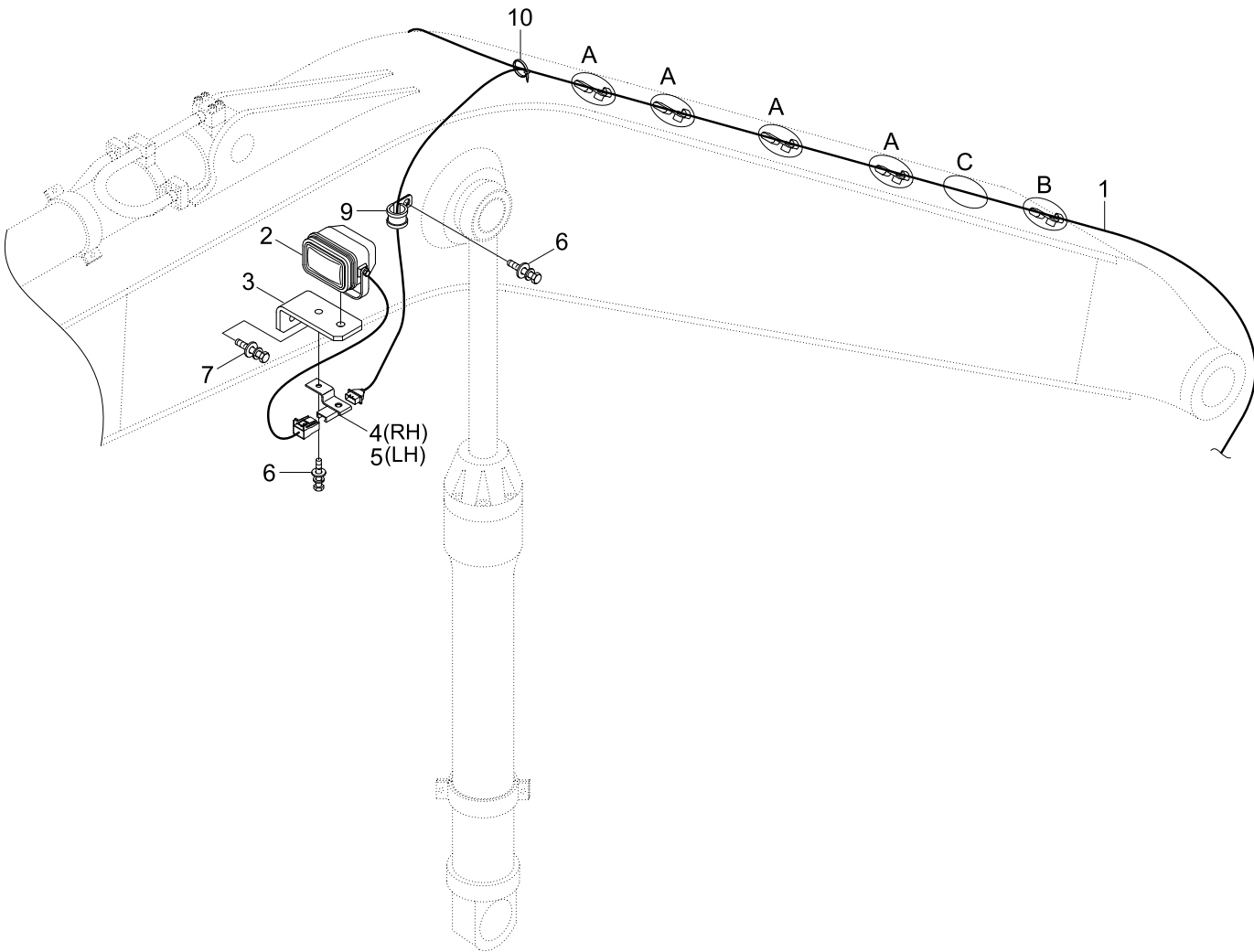

DETAIL A

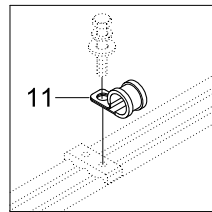

DETAIL B

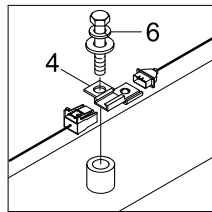

DETAIL C

Item	Part_No	IS	Ord	T	Description	Qty	Serial_No	ITC	Remark
1	21N3-10020				HARNESS-BOOM	1			
2	21N6-20211				WORK LAMP ASSY	2			
2-1	S866-240650				.BULB	1			NOT SHOWN
3	21N6-20221				BRACKET-LIGHT	2			
4	25D1-10640				CLIP ASSY	2			
5	25D1-10650				CLIP ASSY	1			
6	S035-102016				BOLT-W/WASHER	5			
7	S037-122522				BOLT-W/WASHER	2			
8	S593-000652				CLIP-HARNESS	4			
9	S593-000902				CLIP-HARNESS	2			
10	S552-035146				CLAMP-BAND	6			
11	S543-160002				CLAMP-TUBE	1			

# TRAVEL REDUCTION GEAR(TYPE 1)

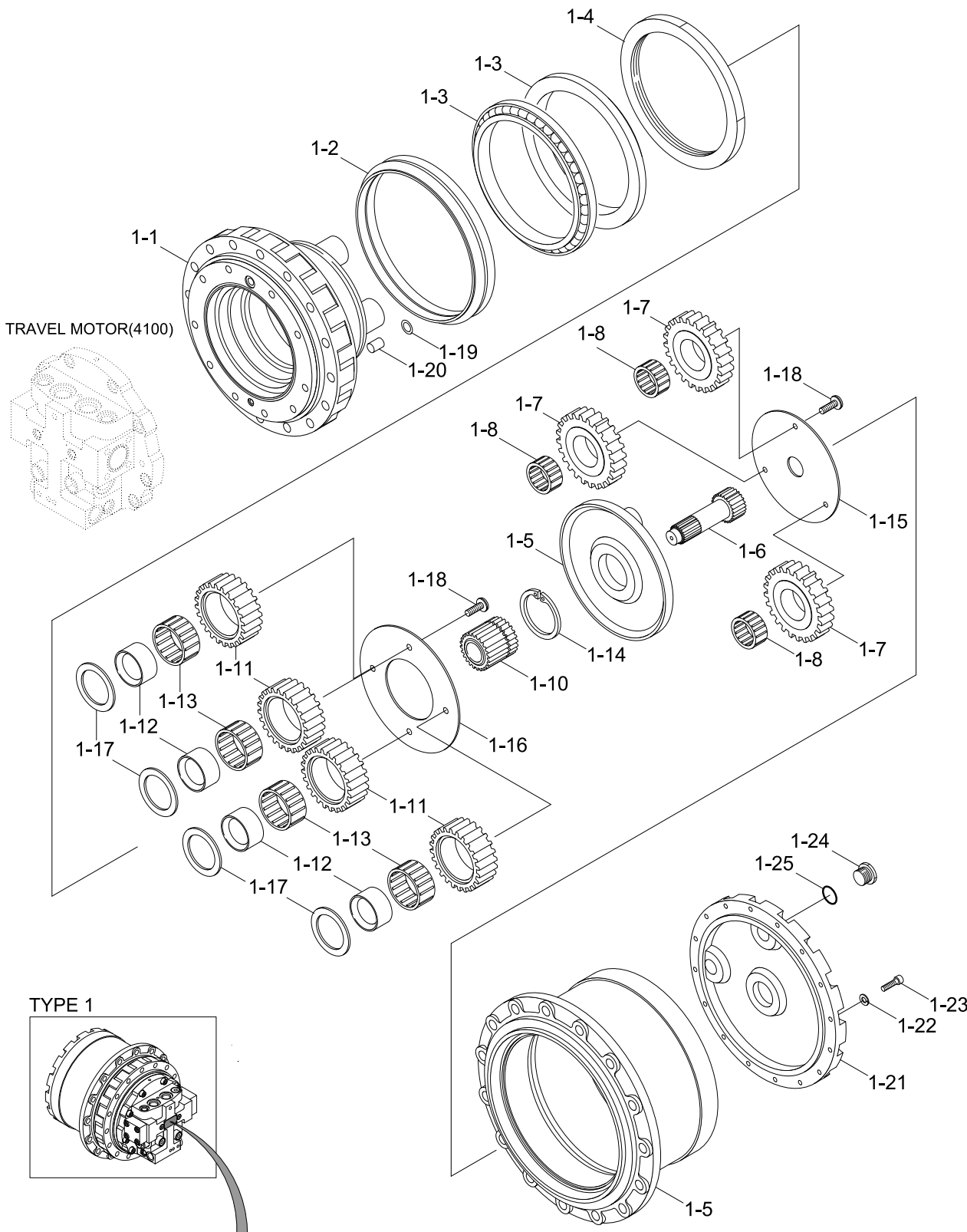

Type	Travel motor	Serial no	Remark
TYPE 1	31N3-40010	#0001-	When ordering, check part no of travel motor assy on name plate.
TYPE 2	31N3-40030	#0535-	

Description	Parts no	Included item
Travel motor seal kit	XJDG-00141	1-25, 13, 30~35, 40, 48, 55, 59, 60-11~60-17, 62, 66, 75, 78

Item	Part_No	IS	Ord	T	Description	Qty	Serial_No	ITC	Remark
*	@				TRAVEL MOTOR	1			NOT
*-1	XJDG-00001				..TRAVEL GEAR ASSY	1			
1-1	XJDG-00002				..BODY-CASING	1			
1-2	XJDG-00004				..SEAL-FLOATING	1			
1-3	XJDG-00005				..BEARING-ANGULAR	2			
1-4	XJDG-00006				..NUT-RING	1			
1-5	XJDG-00007				..GEAR-CASING	1			
1-6	XJDG-00008				..GEAR-SUN A	1			
1-7	XJDG-00009				..GEAR-PLANETARY A	3			
1-8	XJDG-00010				..BEARING-NEEDLE A	3			
1-9	XJDG-00011				..CARRIER	1			
1-10	XJDG-00012				..GEAR-SUN B	1			
1-11	XJDG-00013				..GEAR-PLANETARY B	4			
1-12	XJDG-00014				..BUSHING	4			
1-13	XJDG-00015				..BEARING-NEEDLE B	4			
1-14	XJDG-00016				..RING-SNAP	1			
1-15	XJDG-00017				..PLATE-THRUST (2)	1			
1-16	XJDG-00018				..PLATE-THRUST (3)	1			
1-17	XJDG-00019				..PLATE-THRUST (4)	4			
1-18	XJDG-00020				..SCREW	9			
1-19	XJDG-00021				..WASHER	1			
1-20	XJDG-00022				..PIN-PARALLEL	1			
1-21	XJDG-00023				..COVER	1			
1-22	XJDG-00024				..WASHER-SPRING	16			
1-23	XJDG-00025				..BOLT	16			
1-24	XJDG-00027				..PLUG	2			

Item	Part_No	IS	Ord	T	Description	Qty	Serial_No	ITC	Remark
K1-25	XJDG-00028				..O-RING	2			
K	XJDG-00141				SEAL KIT	1			SEE ILLUSTR

# LOWER FRAME & COVER

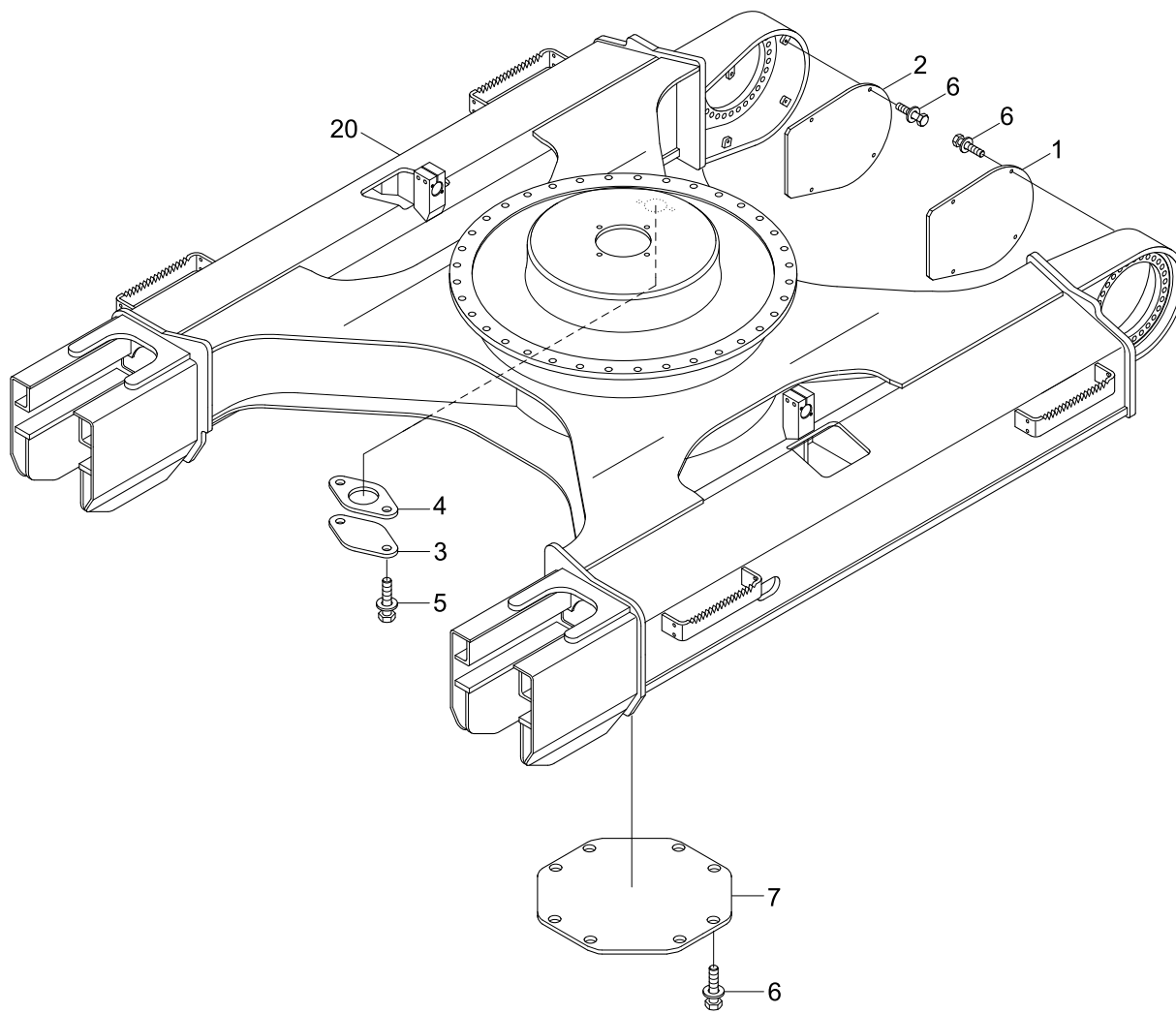

Item	Part_No	IS	Ord	T	Description	Qty	Serial_No	ITC	Remark
1	51N3-11011				COVER WA-T/MOTOR,LH	1	- #0464		
	53N3-11010				COVER WA-T/MOTOR,LH	1	#0465 -	D	
2	51N3-11021				COVER WA-T/MOTOR,RH	1	- #0464		
	53N3-11020				COVER WA-T/MOTOR,RH	1	#0465 -	D	
3	E141-1305	40			COVER	1	- #0464		
	53N3-13050	40			COVER	1	#0465 - #0544	D	
	41N6-10100	40			COVER	1	#0545 -	A	
4	41E9-1306	10			SEAL	1			
5	S037-102052				BOLT-W/WASHER	2			
6	S037-123552				BOLT-W/WASHER	12			
7	51N3-11050				COVER-BOTTOM	1	- #0464		
	53N3-11050				COVER-BOTTOM	1	#0465 -	D	
20	51N3-01012				LOWER FRAME WA	1	- #0464		STD
	53N3-01010				LOWER FRAME WA	1	#0465 -	D	STD
	51N3-04010				LOWER FRAME WA	1	- #0464		D/BLADE
	53N4-04010				LOWER FRAME WA	1	#0465 -	D	D/BLADE



# OIL COOLER

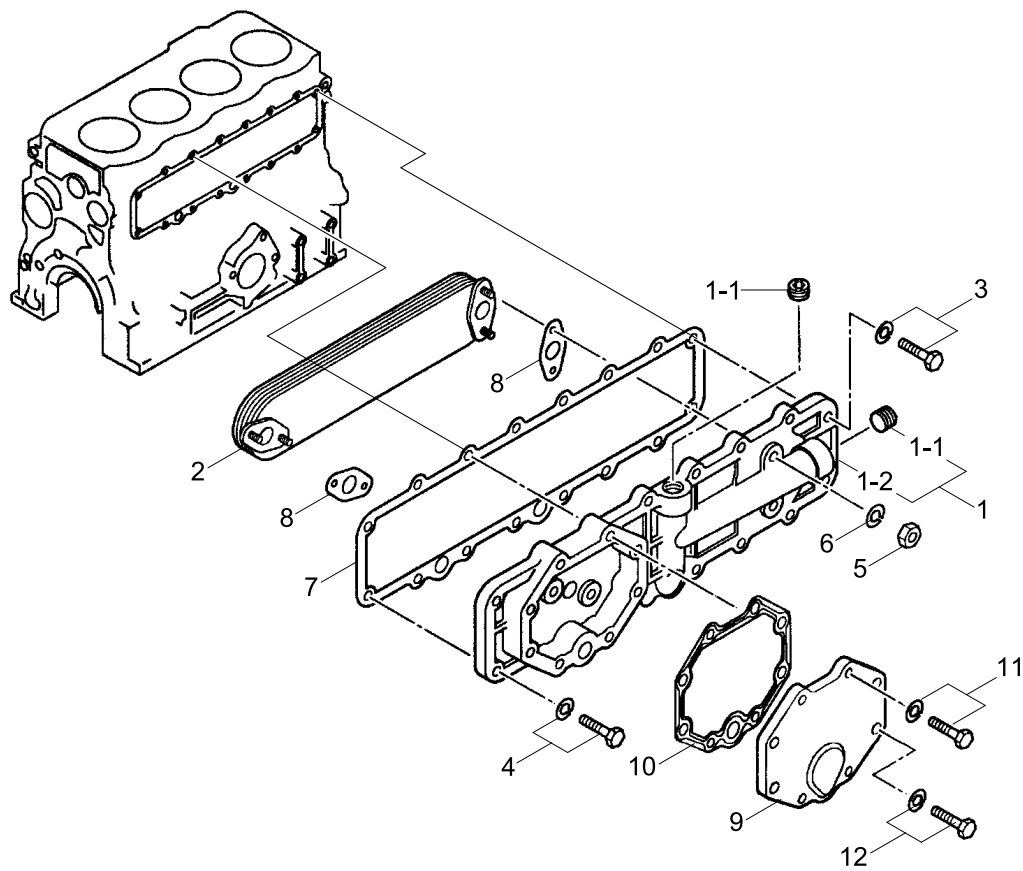

Item	Part_No	IS	Ord	T	Description	Qty	Serial_No	ITC	Remark
1	XJAF-00377				COVER ASSY-COOLER	1			
1-1	XJAF-00378				.PLUG-TAPERED	2			
N1-2	@				.COVER-OIL COOLER	1			NOT
2	XJAF-00386				ELEMENT-OIL COOLER	1			
3	XJAF-00230				BOLT-W/WASHER	3			
4	XJAF-00379				BOLT-W/WASHER	9			
5	XJAF-00380				NUT-LOCK	4			
6	XJAF-00255				WASHER-SPRING	4			
7	XJAF-00381				GASKET-OIL COOLER	1			
8	XJAF-00382				GASKET-O/C ELEMENT	2			
9	XJAF-00383				COVER-FILTER	1			
10	XJAF-00384				GASKET-FILTER	1			
11	XJAF-00385				BOLT-W/WASHER	4			
12	XJAF-00263				BOLT-W/WASHER	4			
N	@				NOT INDIVIDUALLY SUPPLIED	AR			NOT