



Mechanical Separation  
Division

**Westfalia Separator  
Mineraloil Systems GmbH**

## **Instruction Manual and Parts List**

**No.:** 2057-9001-020

**Edition:** 0905

**Designation:** Mineral oil centrifuge with self-cleaning bowl

**Model:** OSD 35-0136-067  
OSD 35-0196-067

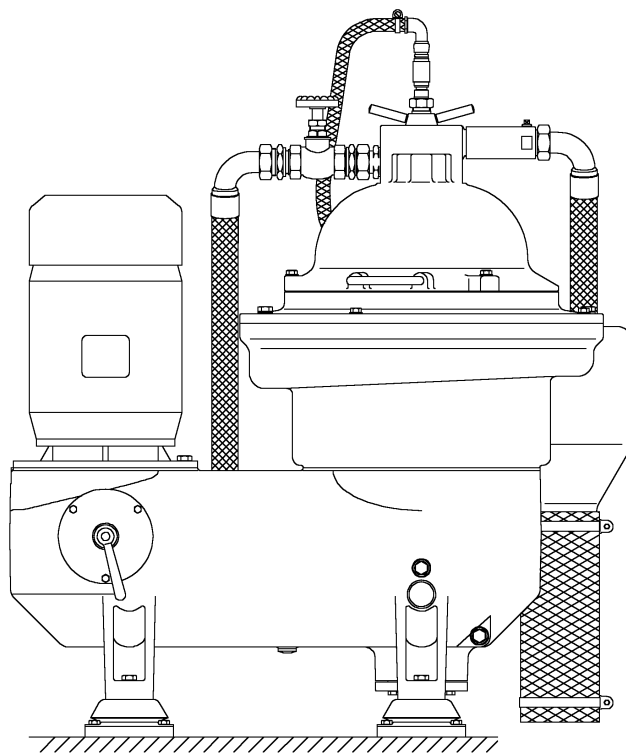



Subject to modification!

The authors are always grateful for comments and suggestions for improving the documentation. They can be sent to

GEA Westfalia Separator Mineraloil Systems GmbH  
Werner-Habig-Str. 1  
D-59302 Oelde

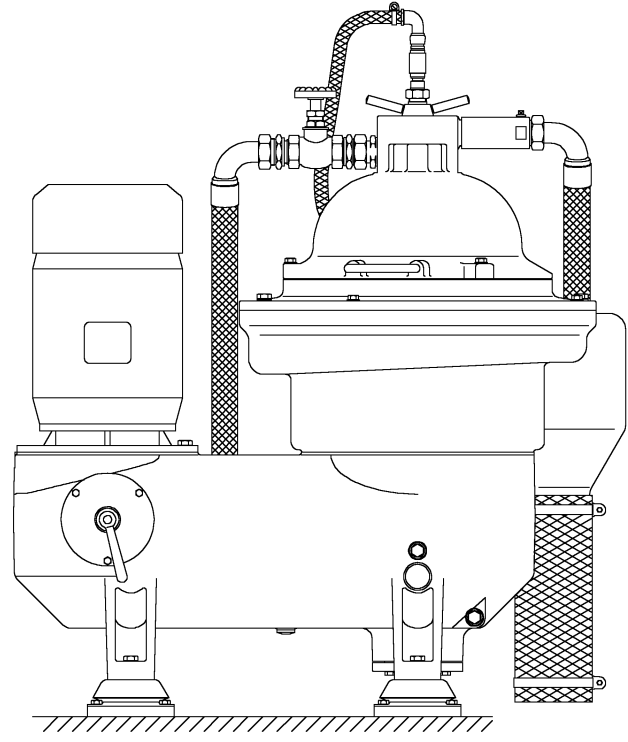
© GEA Westfalia Separator



 <b>Westfalia Separator</b> D-59302 Oelde (F. R. Germany)		Mineraloil Systems GmbH	
Model	<input type="text"/>	S/N	<input type="text"/>
Built in	<input type="text"/>	Ø in mm	<input type="text"/>
Max. admissible rated bowl speed in min <sup>-1</sup>			<input type="text"/>
Max. admissible density in kg/dm <sup>3</sup> of product			<input type="text"/>
Heavy liquid kg/dm <sup>3</sup>	<input type="text"/>	Solids kg/dm <sup>3</sup>	<input type="text"/>
min/max throughput m <sup>3</sup> /h			<input type="text"/>
min/max temp. of product in °C			<input type="text"/>
min/max housing in bar			<input type="text"/>

*This nameplate must be filled in by the operator.  
Please transfer the data from the centrifuge nameplate.*

## For your safety



- **Strictly adhere to instructions marked with this symbol.**  
This avoids damage to the separator and other equipment.



- **Take special care when carrying out operations marked with this symbol -**  
otherwise danger to life.

**Note:**

- This symbol is not a safety precaution but rather a reference to information which help to better understand the separator or plant components and the processes.

- **Observe the accident prevention regulations!**

The local safety and accident prevention regulations apply unconditionally to the operation of the separator. The plant operator must ensure compliance with these regulations.

- **Follow the instructions in the manual.**

Follow only the instructions given in this manual.  
Repair and maintenance work that goes beyond the scope described in this manual may not be carried out.

- **Operate the separator only in accordance with agreed process and operating parameters**

- **Maintain the separator**

as specified in this manual.

- **Carry out safety checks on the separator,**

as described in chapter "Safety precautions" in this manual

- **Liability for the function of the machine passes to the owner.**

Liability for the function of the machine passes unconditionally to the owner or operator irrespective of existing warranty periods in so far as the machine is improperly maintained or serviced by persons other than Westfalia Separator service personnel or if the machine is not applied in accordance with the intended use.

Westfalia Separator shall not be liable for damage which occurs as a result of non-observance of the above. Warranty and liability conditions in the Conditions of Sale and Delivery of Westfalia Separator are not extended by the above.

<b>1</b>	<b>Safety precautions</b>	<b>9</b>
1.1	Correct usage .....	10
1.2	Safety markings .....	10
1.2.1	Safety markings and their meaning .....	11
1.3	Basic operating principles .....	14
1.4	Bowl speed and product .....	14
1.5	Demands relating to service personnel and spare parts .....	15
1.6	Operations on the separator .....	16
1.6.1	Assembly .....	16
1.6.2	Electrical appliances .....	18
1.6.3	Before start-up .....	18
1.6.4	Starting.....	21
1.6.5	Shut-down and »Emergency-Off« .....	23
1.6.6	Maintenance and repair .....	24
1.7	Corrosion .....	27
1.8	Erosion.....	28
<b>2</b>	<b>Machine description</b>	<b>31</b>
2.1	Dimensioned drawing of the separator .....	32
2.2	Section through separator .....	34
2.3	General .....	35
2.4	OSD ...-0136-... and OSD ...-0196-... .....	35
2.4.1	Separator with water content monitoring system (WMS only!) for fuel oil treatment (design -0136-) (for operation in series) .....	37
2.4.2	Separator with sludge space monitoring system (SMS only!) for fuel oil treatment (design -0136-) (for operation in series) .....	38
2.4.3	Separator with sludge space monitoring system (SMS only!) for lube oil treatment (design -96-) .....	39
2.4.4	Separator with WMS and SMS for lube oil treatment (design -0196-) ..	40
2.5	Main components of the separator .....	41
2.5.1	Bowl .....	42
2.5.2	Bowl hydraulics .....	43
2.5.3	Centripetal pump .....	46
2.5.4	Sensing liquid pump .....	47
2.5.5	Drive.....	48
2.6	Technical data .....	49
<b>3</b>	<b>Operation</b>	<b>51</b>
3.1	Technical information.....	52
3.1.1	Separation .....	52
3.1.2	Notes for separation with the UNITROL system.....	52
3.1.3	General information on bowl ejection .....	52
3.2	Before start-up .....	54
3.2.1	Before the <u>first</u> start-up .....	54
3.2.2	Before <u>every</u> start-up .....	54
3.3	Starting the separator .....	55
3.4	Monitoring of operation .....	55
3.5	Setting the separation time .....	56

3.5.1	Mathematical calculation .....	56
3.6	Ejecting the bowl.....	57
3.7	Shutting down the separator.....	58
3.8	Trouble shooting .....	60
3.8.1	Faults on the separator.....	60
3.8.2	Bowl faults .....	62

<b>4</b>	<b>Installation - Maintenance - Repair</b>	<b>69</b>
----------	--	-----------

4.1	Installation of the separator .....	70
4.1.1	Transporting the separator .....	72
4.1.2	Installing the separator .....	73
4.1.3	Motor .....	74
4.1.4	Direction of rotation of the bowl .....	75
4.1.5	Speed and starting time of the bowl .....	76
4.2	Maintenance and lubrication.....	78
4.2.1	Maintenance schedule.....	78
4.2.2	Hoses and hose pipes .....	81
4.2.3	Lubrication .....	82
4.2.4	Lubrication Chart .....	84
4.3	Bowl .....	86
4.3.1	Dismantling the bowl.....	88
4.3.2	Cleaning the bowl .....	102
4.3.3	Cleaning the frame .....	103
4.3.4	Cleaning the strainer and the operating water feeding system .....	103
4.3.5	Important instructions .....	104
4.3.6	Assembling the bowl.....	106
4.3.7	Replacing the polyamide gasket in the annular piston .....	119
4.3.8	Replacing the polyamide gasket (bowl top).....	127
4.4	Closing the hood.....	129
4.5	Motor and centrifugal clutch .....	131
4.6	Drive.....	132
4.6.1	Important instructions .....	134
4.6.2	Removing the drive belt and spindle assembly .....	136
4.6.3	Dismantling the spindle assembly .....	141
4.6.4	Removing the centrifugal clutch .....	143
4.6.5	Fitting the spindle assembly .....	147
4.6.6	Fitting the centrifugal clutch .....	150
4.6.7	Replacing the neck bearing springs (neck bearing bridge) .....	156
4.6.8	Fitting the motor.....	159
4.7	Height adjustment.....	162
4.7.1	Bowl height .....	162
4.7.2	Centripetal pump clearance.....	164
4.8	Final checks after assembling the separator .....	166
4.9	Before a long-term shut-down of the separator .....	166
4.10	Before restarting .....	167
4.11	Standard tools.....	168

<b>5</b>	<b>Accessories</b>	<b>171</b>
----------	--------------------	------------

5.1	Solenoid valve block .....	172
5.2	Solenoid valves.....	174
5.3	Pressure switch .....	175

<b>6</b>	<b>Parts list</b>	<b>179</b>
----------	-------------------	------------

Guide to ordering spare parts .....	181
Set of plates.....	183
Frame, compl.....	185
Brake bolt, compl.....	186
Solenoid valve block, complete .....	187
Solenoid valve block, compl. ....	188
Drive, complete – 50 Hz .....	191
Drive, complete – 60 Hz .....	191
Neck bearing bridge, compl.....	192
Spindle assembly .....	195
Bearing bush, complete.....	195
Centrifugal clutch, compl. – 50 Hz.....	197
Centrifugal clutch, compl. – 60 Hz.....	197
Bowl, complete .....	199
Accessories for the separating disk (for version -0136-).....	200
Disk stack, compl.....	201
Hood, compl. ....	205
Solenoid valve, compl. ....	206
Water feed line, compl.....	207
Corrugated hose, compl. ....	208
Set of tools and accessories .....	211
Lubricants (hazardous materials!).....	211
Spare parts "bowl/hood" (operation: 1 year or 8,000 hours).....	213
Set of spare parts "drive" – 50 Hz (operation: 1 year or 8000 operating hours).....	215
Set of spare parts "drive" – 60 Hz (operation: 1 year or 8,000 operating hours).....	215
Set of spare parts "drive" – 50 Hz (operation: 2 years or 16,000 operating hours).....	217
Set of spare parts "drive" – 60 Hz (operation: 2 years or 16,000 operating hours).....	217

<b>7</b>	<b>Appendix</b>	<b>219</b>
----------	-----------------	------------

7.1 Table of lubricating oils .....	220
7.1.1 Comments on table of lubricating oils for separators from Westfalia Separator .....	221
7.2 The health hazards involved when handling heavy oils and lube oils.....	222
7.2.1 Code of practice and personal protective measures .....	222

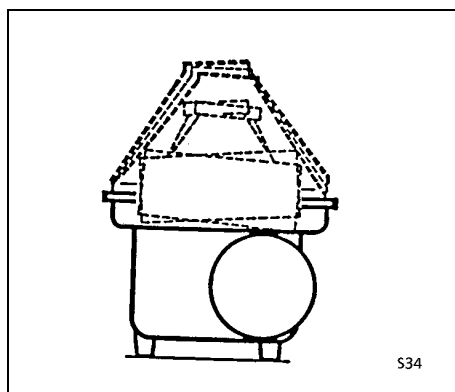

Fig. 14

- After installing certain critical spare bowl parts, the bowl must be re-balanced.

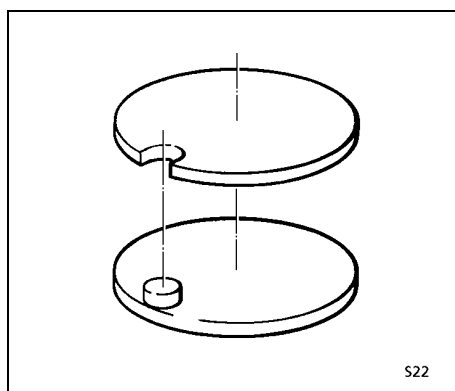

Fig. 15

- The bowl parts are arranged in fixed positions relative to one another.
- Locking devices and alignment marks must be in perfect condition. The bowl must not be operated if these locking devices and alignment marks are not in perfect condition.

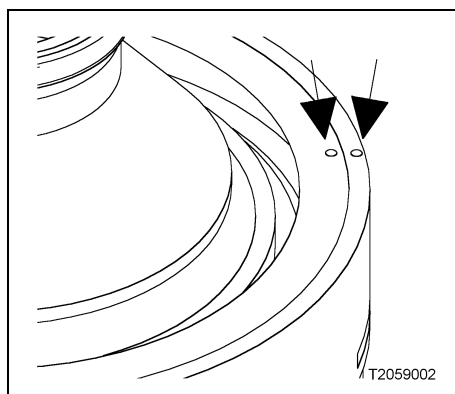

Fig. 16

- When assembling the bowl, be sure to strictly adhere to the instructions given in chapter "bowl", in order to avoid undue unbalance.
- Before starting the bowl, be sure to fit all parts.
- Tighten the bowl lock ring **securely**: the "O" marks on the bowl bottom or bowl top and on the lock ring must be in line with each other.

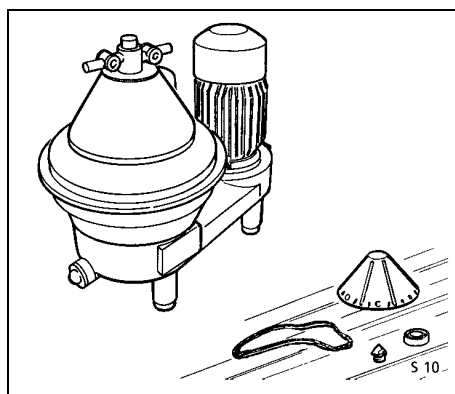

Fig. 17

- Check if the machine is completely assembled and properly installed.



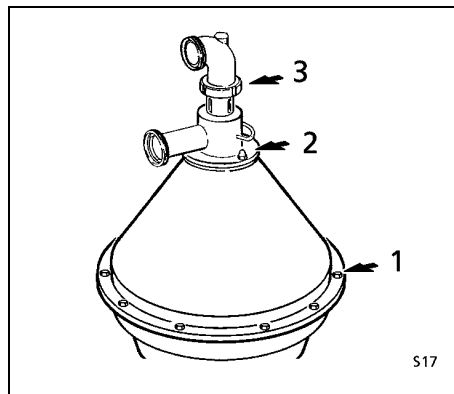

Fig. 18

- Carefully fasten hood 1, feed and discharge housing 2 and centripetal pump 3.

### 1.6.2 Electrical appliances

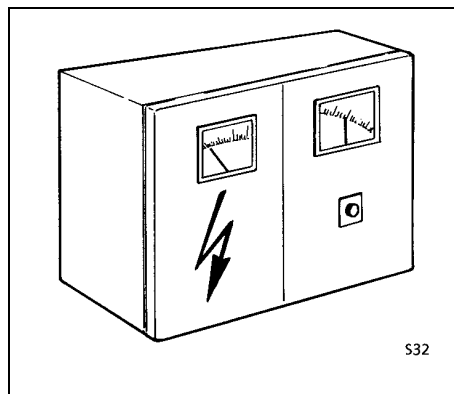

Fig. 19

- The governing accident prevention regulations apply for the electrical appliances and installations.
- The frequency and voltage of the power supply must correspond to the machine specifications.
- Carry out voltage equalization.
- Observe legal regulations; e.g. in the EU:
  - Low-voltage guideline 73/23/EWG
  - Electro-magnetic compatibility 89/336/EWG.

### 1.6.3 Before start-up

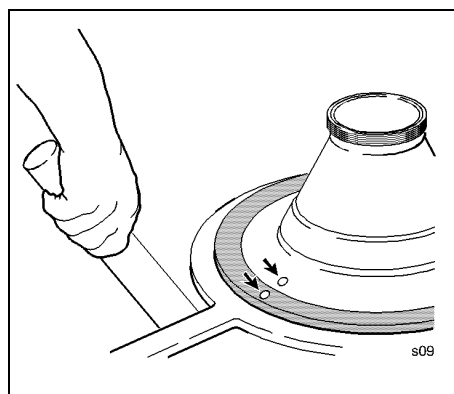

Fig. 20

- Check that the bowl lock ring has been **firmly** tightened.
- The "O" marks on bowl bottom or bowl top and on the lock ring must be aligned.

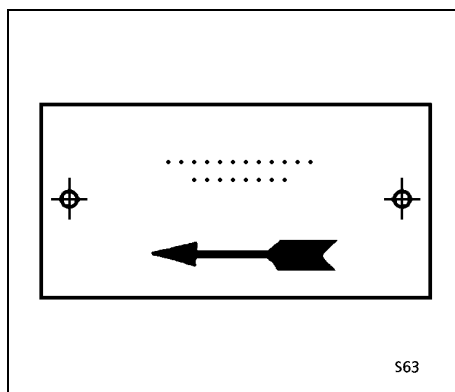

Fig. 21

- The bowl must rotate in clockwise direction (see arrow on frame or solids collector).

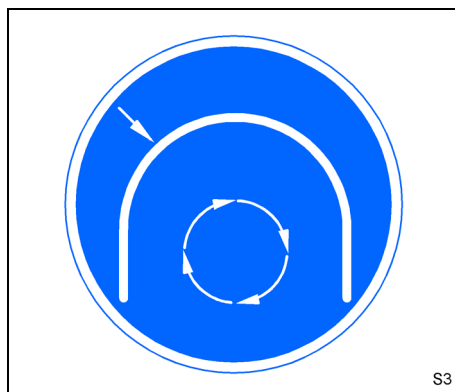

Fig. 22

- The separator may only be operated with protection devices conforming to EN 294. Equip solid and liquid discharges accordingly.

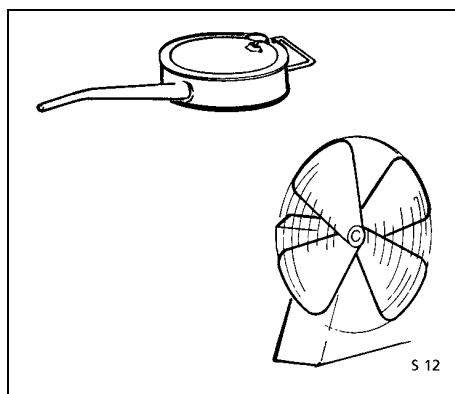

Fig. 23

- Check that the lubrication and cooling systems are serviceable.

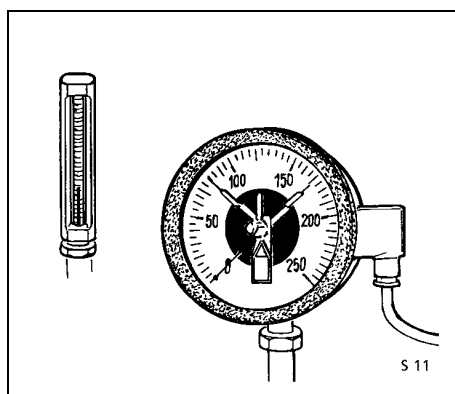

Fig. 24

- Check whether the supervisory equipment is operational and the correct limit values are adjusted.
- When hoods, concentrate collectors and vessels are pressurized, e.g. by
  - inert gas,
  - cooling,
  - steam sterilization etc.
 the pressures stated on the nameplate must not be exceeded.

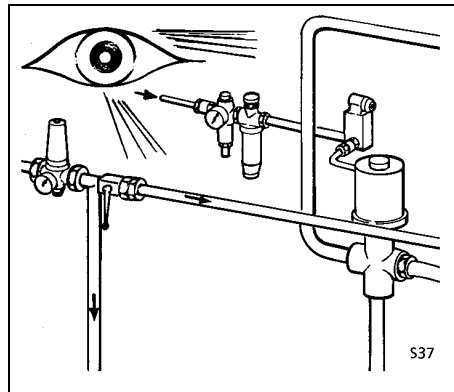

Fig. 25

- Check that the product lines are set to operation.
- Regularly check hoses for signs of ageing.
- Check sight glasses for mechanical damage.
- Replace damaged parts by reconditioned or new parts.

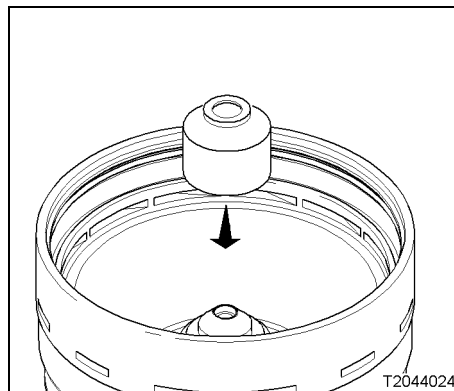

Fig. 202

- Insert the pressure piece.

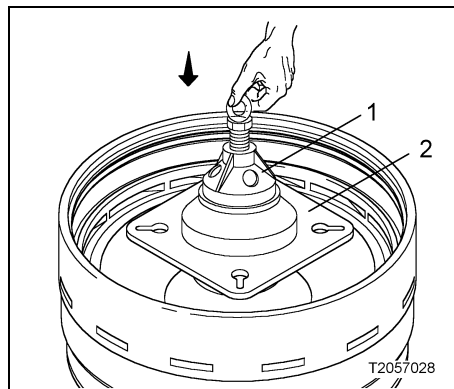

Fig. 203

- Position plate 2 and assembling device 1.
- Insert assembling device in the bowl bottom.

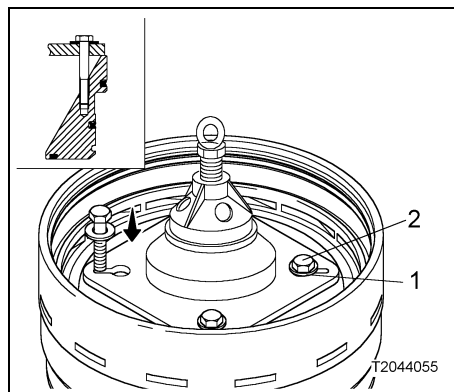

Fig. 204

- Screw the assembling device onto closing chamber bottom as illustrated:
  - with four washers 1 (8.4x24x2) and
  - with four hex head screws 2 (M 8x55).

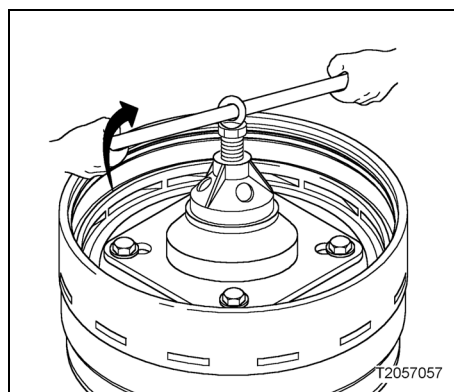

Fig. 205

- Lower the closing chamber bottom by turning the spindle **counter-clockwise**.

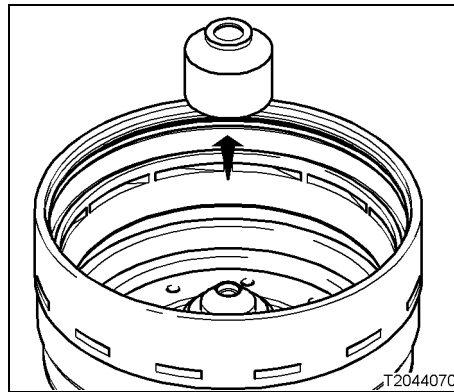

Fig. 206

- Remove the pressure piece.

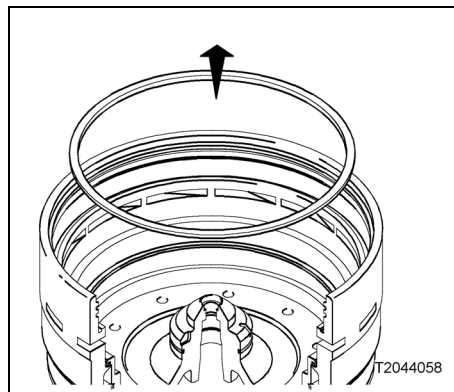

Fig. 207

- Remove the mounting ring.

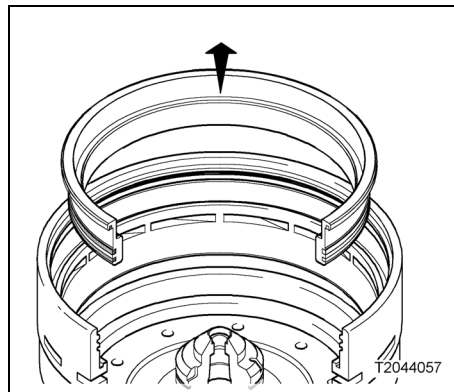

Fig. 208

- Remove the annular piston.

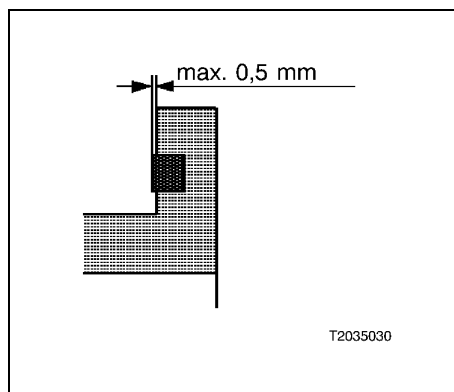

Fig. 209

If the dimension of the pressed-in gasket is **more than 0.5 mm**,

- the polyamide gasket must be further pressed in the vice.

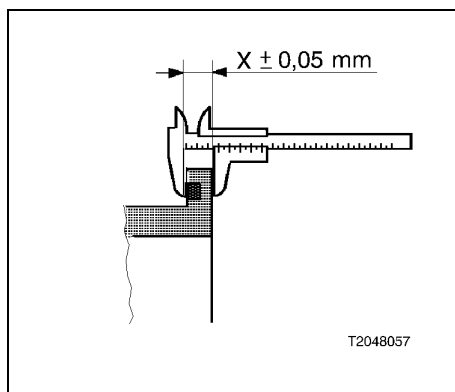

Fig. 210

- By carrying out **several measurements** around the entire circumference of the annular piston, check that the polyamide gasket is seated **parallel** in the groove.

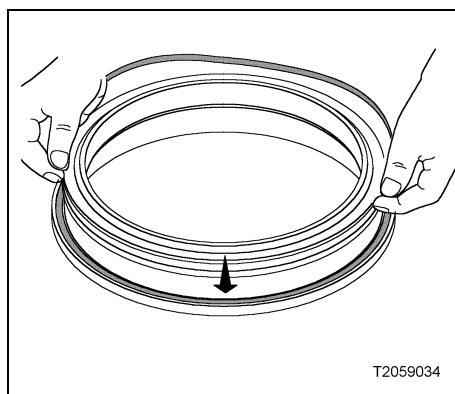

Fig. 211

#### FITTING – VARIANT II

- Thoroughly clean and dry the groove.
- Heat the gasket in approx. 80 °C (176 °F) water for 5 minutes.
- Gasket:
  - clean and wipe dry
  - lightly press into the groove.

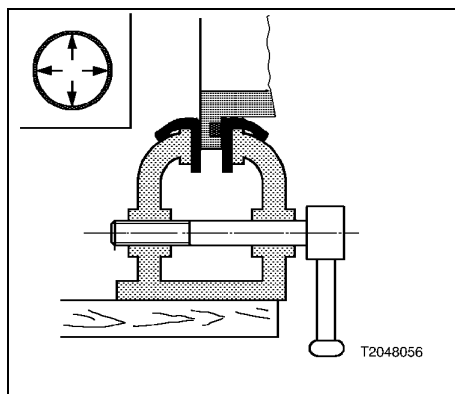

Fig. 212

- Pull the polyamide gasket into the groove applying a vice at four diametrically opposite points.
- Then
- pull the gasket bit by bit into the groove with the vice.

**Use smooth copper jaws.**

## 6 Parts list

Guide to ordering spare parts.....	181
Set of plates.....	183
Frame, compl.....	185
Brake bolt, compl.....	186
Solenoid valve block, complete .....	187
Solenoid valve block, compl.....	188
Drive, complete – 50 Hz .....	191
Drive, complete – 60 Hz.....	191
Neck bearing bridge, compl.....	192
Spindle assembly .....	195
Bearing bush, complete.....	195
Centrifugal clutch, compl. – 50 Hz.....	197
Centrifugal clutch, compl. – 60 Hz.....	197
Bowl, complete .....	199
Accessories for the separating disk (for version -0136-).....	200
Disk stack, compl.....	201
Hood, compl. ....	205
Solenoid valve, compl. ....	206
Water feed line, compl.....	207
Corrugated hose, compl. ....	208
Set of tools and accessories .....	211
Lubricants (hazardous materials!).....	211
Spare parts "bowl/hood" (operation: 1 year or 8,000 hours).....	213
Set of spare parts "drive" – 50 Hz (operation: 1 year or 8000 operating hours).....	215
Set of spare parts "drive" – 60 Hz (operation: 1 year or 8,000 operating hours).....	215
Set of spare parts "drive" – 50 Hz (operation: 2 years or 16,000 operating hours).....	217
Set of spare parts "drive" – 60 Hz (operation: 2 years or 16,000 operating hours).....	217

### Guide to ordering spare parts

A rapid and correct supply of spare parts can only be guaranteed if your order includes the following details:

- Separator model            see nameplate  
   e.g. OSD 35-0136-067
- Serial-No.                    see nameplate  
   e.g. 9000-223
- Designation                 see parts list  
   e.g. frame
- Part-No.                      see parts list  
   e.g. 2050-1100-020  
   The part number is also marked on almost all the individual parts.

Only when ordering spare parts for bowls:

- Bowl S/N                      see bowl lock ring, bowl bottom or bowl shell  
   if different from the machine serial number.

Only required when ordering spare parts for pump and pump connection parts:

- Model and number of pump    see pump nameplate

The details **must** be complete when the part number ends with a letter (e.g. 2050-6600-L), since this indicates that the parts are available in different designs.



Fig. 320

- **Use only genuine spare parts from Westfalia Separator.**

The use of non-genuine parts leads to:

- safety risks,
- less durability and availability,
- increased service requirement.

If a safety risk occurs, this may have legal consequences for the responsible persons. In such cases, Westfalia Separator accepts no liability or warranty claims.



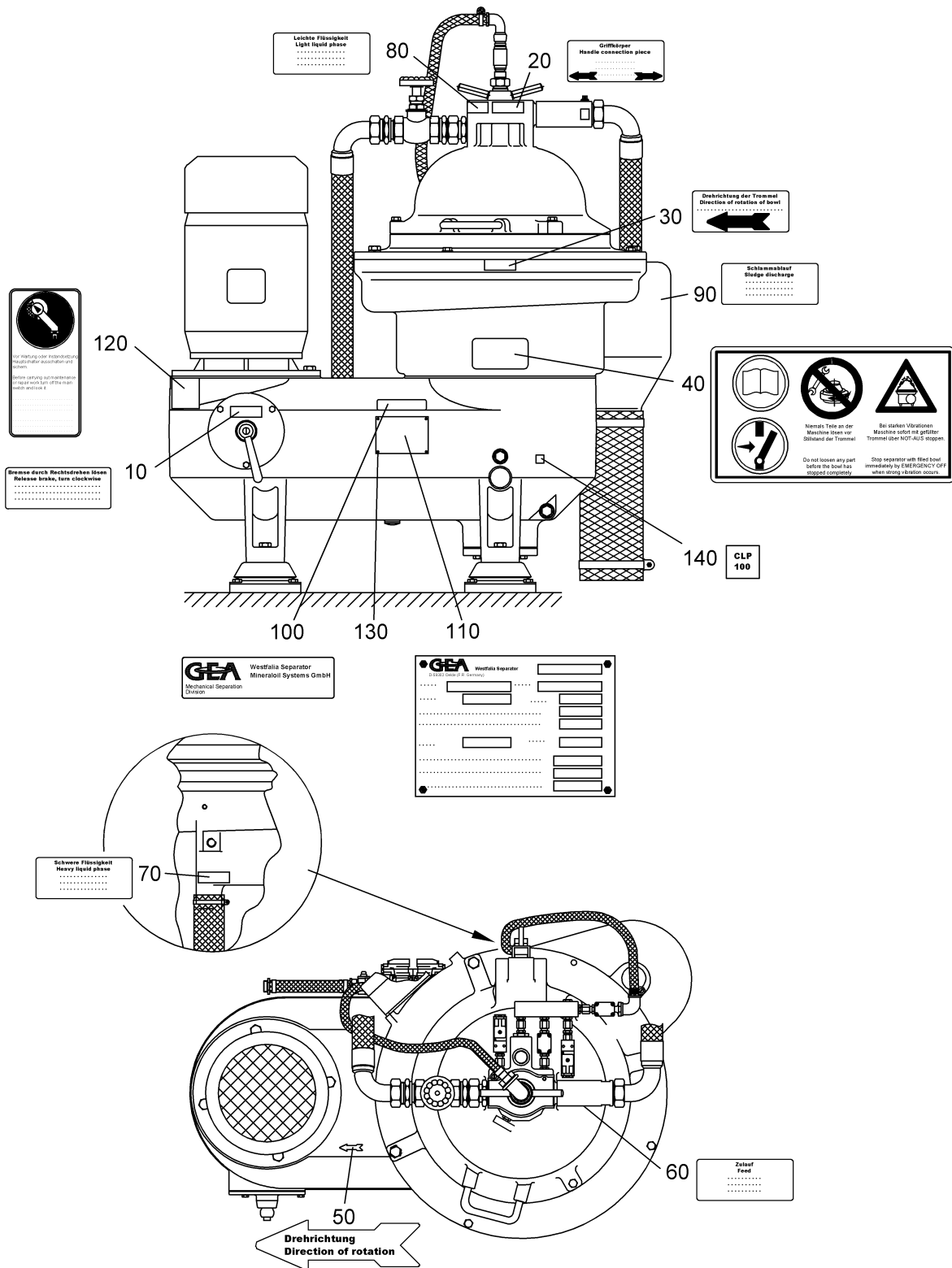

0024-4310-00001

Fig. 321

Pos.	Part Number	Qty.	Designation
-	<b>0024-4310-000</b>	<b>1</b>	<b>Set of plates</b>
10	0024-6324-000	1	Adhesive plate
20	0024-6327-000	1	Adhesive plate
30	0024-6326-000	1	Adhesive plate
40	0024-6426-000	1	Plate
50	0024-6071-000	1	Decal "arrow"
60	0024-6330-000	1	Adhesive plate
70	0024-6329-000	1	Adhesive plate
80	0024-6328-000	1	Adhesive plate
90	0024-6325-000	1	Adhesive plate
100	0024-6334-000	1	Maker's nameplate
110	0024-3413-000	1	Nameplate
130	0026-1571-300	4	Grooved drive stud
140	0024-5049-000	1	Adhesive plate

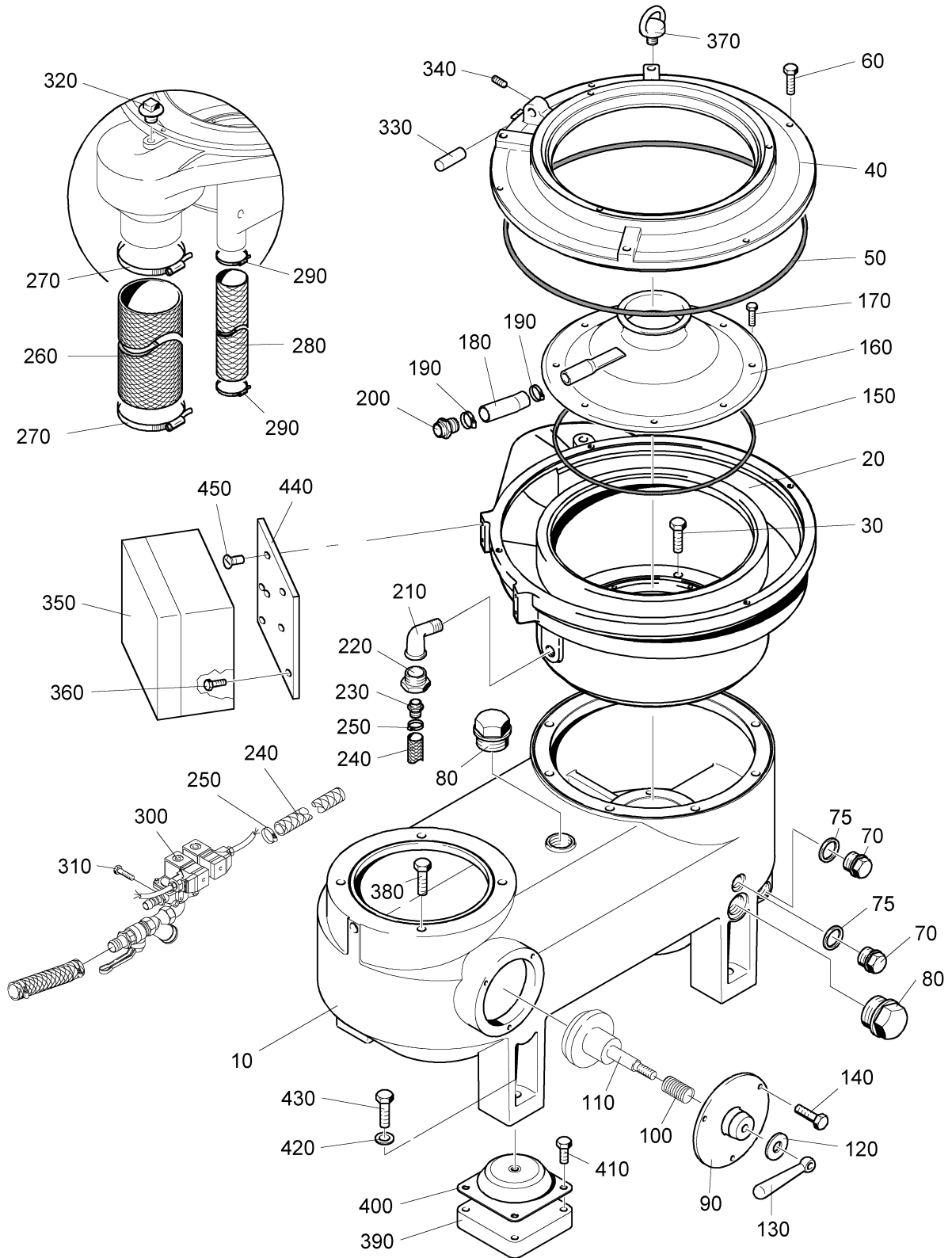

2057-1100-000

Fig. 322