



SULZER

RLA/RLB76

Operating Manual

“Marine”

Vessel:

Type:

Engine No.:

Book No.:

Wärtsilä Switzerland Ltd
PO Box 414
CH-8401 Winterthur
Switzerland

24hrs Support: +41 52 262 80 10
technicalsupport.chts@wartsila.com

List of Groups	General	0
	Crankcase Tie bolts	1
	Main cylinders	2
	Crankshaft Running gear Turning gear	3
	Control system	4
	Governor Overspeed system Fuel injection pumps Control linkage	5
	Charge air receiver Auxiliary blower Exhaust gas turbocharger Charge air cooler	6
	Cylinder lubrication	7
	Pipe systems	8
	Measuring instruments	9

For Particular Attention

This manual is put at the disposal of the recipient solely for use in connection with the corresponding type of Sulzer diesel engine.

It has always to be treated as confidential.

The intellectual property regarding any and all of the contents of this manual, particularly the copyright, remains with **Wärtsilä Switzerland Ltd**. This document and parts thereof must not be reproduced or copied without their written permission, and the contents thereof must not be imparted to a third party nor be used for any unauthorized purpose.

Before the operator intends to use the engine or before maintenance work is undertaken, the Operating Instructions or the Maintenance Manual respectively is to be read carefully.

To ensure the best efficiency, reliability and lifetime of the engine and its components, only original spare parts should be used.

It is to be ensured as well that all equipment and tools for maintenance are in good condition.

The extent of any supplies and services is determined exclusively by the relevant supply contract.

The data, instructions and graphical illustrations etc. in this manual are based on drawings made by **Wärtsilä Switzerland Ltd** and correspond to the actual standard at the time of printing (year of printing is indicated on title page).

Those specifications and recommendations of the classification societies which are essential for the design have been considered therein. It must be recognized that such data, instructions and graphical illustrations may be subject to changes due to further development, widened experience or any other reason.

This manual is primarily intended for use by the engine operating and maintenance personnel. It is assumed that it will always be at the disposal of such personnel for the operation of the engines and/or for the required maintenance work.

This manual has been prepared on the assumption that operation and maintenance of the engines concerned will always be carried out by personnel having the special knowledge, training and qualifications needed to handle in a workman-like manner diesel engines of the corresponding size, the associated auxiliary equipment, as well as fuel and other operating media.

Therefore, generally applicable rules, which may also concern such items as protection against danger, are specified in this manual in exceptional cases only.

It must be assumed that the operating and maintenance personnel are familiar with the rules concerned.

This manual has been prepared to the best knowledge and ability of its authors. However, neither Wärtsilä Switzerland Ltd nor their employees assume any liability – under any legal aspect whatsoever – in connection with this manual, its contents, or modifications to it or in connection with its use, including possible negligence.

Further, claims relating to any damage whatsoever or claims of other nature such as demands for additional spares supplies, service or others will not be considered.

Wärtsilä Switzerland Ltd
Winterthur
Switzerland

F O R E W O R D

The following "description and operating instruction" describes the engine, certain engine parts and its function. Further, it contains the important data to operate it. It is presumed that the engine-room staff already possess the necessary general knowledge concerning the operation of diesel engines.

A separate "Maintenance Manual" deals with the upkeep of the engines as well as the tools and devices required to do so. Further it contains tables for clearances and tightening forces for bolt respective stud connections.

The individual engine parts are numbered and listed in a separate "code book". Spare parts are ordered from the code book exclusively.

The subdivisions of the main-and sub groups in the service instruction book, the maintenance manual and the code book are identical.

For the parts built by other firms such as turbocharger, governor etc. please refer to the respective instruction books which at the same time contain the code numbers for spare parts.

In addition to the above mentioned books, setting tables, trial and erection records are also provided.

In the same folder as said records and tables are "Performance data sheets", which should be completed as thoroughly as possible and then sent to the engine builder whenever advice is required in regard to the engine performance. This will help the specialist to give the correct recommendations.

List of Groups**General****0****Crankcase
Tie bolts****1****Main cylinders****2****Crankshaft
Running gear
Turning gear****3****Control system****4****Governor
Overspeed system
Fuel injection pumps
Control linkage****5****Charge air receiver
Auxiliary blower
Exhaust gas turbocharger
Charge air cooler****6****Cylinder lubrication****7****Pipe systems****8****Measuring instruments****9**

L I S T O F C O N T E N T S

For Particular Attention	0
<u>Group O</u>	
<u>General</u>	
Foreword	000
List of groups	001
List of contents and parts	002
Cross-and longitudinal sections through engine	003-20/21
Marking of cylinders and bearings as well as designation of engine side	004
Description of the engine	005
Working principle of the engine	006
Inter-relationships between engine and propeller	007
Operation of engine	008
<u>Service instructions</u>	
General instructions on servicing and operating the engine	020
Preparation before commissioning the engine	021
Priming the fuel system	022
Starting the engine	023
Normal running	024
Pressures and temperatures	025
Overload running	026
Running on heavy fuel oil	027
Manoeuvring	028
Running on low power	029
Running in heavy sea	030
Putting the engine out of commission for extended periods of time	031
Propeller uncoupled	032
Cutting out individual cylinders	033
Running with defective turbocharger(s)	034
Running with defective air cooler(s)	035
Possibilities to stop the engine	036
<u>Specifications</u>	
Fuel specifications	041
Lubricating oil specifications	042
Dimensions and quality of rubber sealing rings	043
Mass (weight) (Approximate mass of individual components for RN.M engines)	045
<u>Special measures</u>	
To prevent fires in the scavenge spaces	051
To prevent explosions in the crankcase	052
To treat the cooling water	053

RL

<u>Operating problems with the engine</u>		
On starting	Summary of operating problems	060
	Engine does not start; hunts or does not gain speed	061
	Engine turns on air; but does not receive fuel	062
	No or heavy ignition on starting	063
	Engine cannot be reversed, or runs only in one direction	064
	Engine can not be stopped	065
In operation	Scavenge air pressure drops	066
	Exhaust temperature before turbocharger rises	066
	Exhaust temperature of a cylinder falls	066
	Engine speed drops	066
	Cylinder(s) knocking	067
	Exhaust smokes; bad combustion	067
	Engine runs irregular or cuts out at times	068
	Engine stops by itself	068
	Jacket cooling water pressure fluctuates	069
	Jacket cooling water outlet temperature rises on some cylinders	069
	Jacket cooling water outlet temperature rises on all cylinders	069
	A piston runs hot	070
	Bearing runs hot	071
	Cylinder lubrication interrupted	072
	Problems on the woodward governor	511-4
	Defects on cylinder	033
	Defects on turbochargers (see separate instruction manual)	034
	Defects on air coolers	035

Description of componentsGroup 1

Crankshaft bearings	117
Thrust bearings	120
Columns, guide rails	142
Tie rods	191

Group 2

Cylinder jackets	211
Cylinder liners	214
Lubricating quills for cylinder lubrication	215
Piston rod glands	231
Cylinder covers and water guide rings	271
Fuel injection valves	272
Starting air valves	274
Safety valves, indicator valves	277

Group 3

Crankshaft	310
Vibration damper	313
Axial damper	314
Turning gear	321
Connecting rod and connecting-rod bearings	330
Crosshead	337
Crosshead lubrication	339
Piston	340
Piston rings	344
Piston cooling	361

Group 4

Pneumatic engine control	
Normal running	400
Emergency running (fixed propeller/variable pitch propeller)	401/402
Pressure reducing station	404
Emergency control air supply unit	405
Camshaft drive	411

Vertical drive	413
Camshaft and fuel cams	421
Reversing servomotor for camshaft	423
Starting air distributor	431
Starting air control valve	434
Automatic starting air shut off valve	436
Reversing control valve	450
Three position cylinder	452
Rotation direction safeguard	453
Shut down servomotor	455
Pneumatic Logic box	463
Emergency manoeuvring stand	480
Control desk in control room	481

Group 5

Governor and tachometer drive	510
Woodward governor	511
Safety cut-out device	530
Fuel injection pumps	551
Regulating linkage	581

Group 6

Scavenge air receiver	641
Turbocharger	651
Auxiliary blower	656
Air coolers	661
Water trap	670

Group 7

Cylinder lubricating system	721
Load dependant cylinder lubricator drive	722
Balancer	770

Group 8

Exhaust manifold	811
Cooling water systems	830
Oil systems	840
Starting air system	869
Fuel system and armatures	877

Group 9

Reading instruments	924
Indicator diagrams	925

ALPHABETICAL SUBJECT INDEX

A

Accumulator for cylinder lubrication	215
Accumulating system for cylinder lubrication	721
Air cooler	661
Air cooler (running with defective cooler)	035
Air cooler defect	035
Assembly of engine	006
Atomizing pressure of fuel injectors	272
Automatic fuel cut-out device, (running direction safety interlock)	400,453
Automatic fuel cut-out servomotor	455
Automatic safety cut-out device	400-461
Auxiliary blower	656
Axial damper	314

B

Bearing oil pressure, engine	840,025
Bearing oil pressure turbocharger (see turbocharger instruction book)	
Bearing pressure bolts, tension bearing hydraulically	117
Bearing running not	071
Beginning of fuel delivery of injector pumps	551
Blocking device for fuel supply	400-20
Blocking device of starting air	400-20,401-20
Blocking device for turning gear	321
Booster pump for fuel oil	027,551,877
Breakdown of engine	060
Breakdown of turbocharger (see turbocharger instruction book)	
Buffer spaces, piston underside	006,051

C

CO ₂ For firefighting	052,148
Camshaft	421
Camshaft bearings	421
Camshaft drive	411
Camshaft driving gears	411
Cams for fuel injection pumps	421
Cams for pilot starting valves	431
Charger (turbocharger, see turbocharger instruction book)	651
Code book	001
Cold weather periods, protection measures	031
Column	148
Combustion, poor combustion	067
Combustion chamber	271
Component masses	045
Compression shims	330
Condensation in air cooler	024
Connecting rod	330

A L P H A B E T I C A L S U B J E C T I N D E X

C

Connecting rod bearing	330
Connecting rod bolts	330
Constand-pressure fuel valve	027,877
Consumption of cylinder lubrication	722
Control box	481
Control desk in control room	481
Control diagram for normal running	400-20
Control diagram for emergency running	401-20
Control oil system	840
Control switches on intermediate shaft	924
Control valve (Pilot valve) for main automatic-starting air shut-off valve	436
Control system	Group 4
Control sequence	400
Control valve-reversing	450
Cooler for scavenge air	661
Cooling water pipes	830
Cooling water system disturbance in..	830,069
Cooling water treatment	053
Crankcase explosions, preventing explosions	052
Crankcase relief valves	052,142
Crankshaft	310
Correcting the fuel pump timing	551
Crosshead	337
Crosshead bearing oil	840
Crosshead guide	142
Crosshead bearing lubrication	339
Cross section of engine	003
Cutting out of individual cylinders	033,551
Cylinder cooling water pressure fluctuates	069
Cylinder cover	271
Cylinder cover studs	271
Cylinder jacket	211
Cylinder liner	214
Cylinder lubrication	721,722
Cylinder lubricatong quills, with non-return valve	215
Cylinder relief valve	277

D

Description of engine	005
Designation of engine sides	004
Diagrams, indicator diagrams	925
Dimension of rubber sealing rings on the engine	043
Direction of rotation	004
Direction indicator	400
Distrubance during operation	060

ALPHABETICAL SUBJECT INDEX

E

Eccentric shaft for fuel injection pumps	551
End of fuel delivery (fuel injection pumps)	551
Effective delivery stroke	551
Effective start of fuel delivery	551
Effective termination of fuel delivery	551
Emergency control air supply unit	405
Emergency fuel lever	400,581
Emergency running (fixed propeller/variable pitch propeller)	028/401/402
Engine cannot be stopped	065
Engine does not start, when pushing starting button	061
Engine misfires	068
Engine runs unevenly and misfires at times	068
Engine speed drops	066
Engine stops by itself	068
Equalizing combustion pressures	551
Exhaust pipes	811
Exhaust ports	214
Exhaust smokes	067
Exhaust temperature drops	066
Expansion pieces for exhaust pipes	811
Explosions, preventing crankcase explosions	052

F

Fire fighting	051
Fires, prevention of fires	051
Flame traps in starting air pipes	869
Flaps in charge air receiver	641
Foreword	000
Frost, precaution against	031
Fuel blocking device	400
Fuel pressure retaining valve	877
Fuel emergency running lever (operation without governor)	036
Fuel lever (speed setting lever)	400,481
Fuel injection pumps	551
Fuel injection valves	272
Fuel injection pump valves	551
Fuel injection nozzles	272
Fuel injection valve body	272
Fuel injection system	027,272,551
Fuel regulating linkage	581
Fuel pipes	027,877
Fuel pump cams	421,551
Fuel system	027,877
Fuel specification	041
Functional description of flaps in charge air receiver	641

ALPHABETICAL SUBJECT INDEX

G

Gear pump for cylinder lubricating oil pump drive	423,722
Gears	Group 3
Gear bearing runs hot	071
Gear wheels, camshaft drive	411
Gear wheels, vertical drive	413
Gland for piston cooling telescopic pipes	361
Gland for piston rod	231
Governor (Woodward)	511
Governor drive	510
Grid before turbine	811
Groups, list of groups	002
Guide rails for crosshead guide shoes	142

H

Heating pipes for fuel system	027,877
Heating of fuel system (heavy oil specification)	027
Heavy fuel oil	027
Heavy fuel operation	027
Heavy oil specification and diagram	027
Hot running of a piston or bearing	070,071
Hydraulic motor for cylinder lubricating oil pump drive	721,722
Hydraulic pump for cylinder lubricating oil pump drive	423,722

I

Ignition, heavy during starting	063
Indicator, load indicator	581
Indicator diagrams	925
Indicator valves	277
Injection system	027,272,551
Injection pressure for fuel injectors	272
Injector nozzle	272
Injectors, fuel injection	272
Inhibitor, corrosion inhibitor for cooling water	053
Instruments, measuring	Group 9
Instructions for heavy oil operation	027
Instructions for operating engine	008
Intermediate gear wheels	411
I V O cylinder lubricating pumps	721

J

Jacks, hydraulic jacks see "Maintenance Manual"

K

Knocking of one cylinder	067
--------------------------	-----

ALPHABETICAL SUBJECT INDEX

L

Limit switch positioning	924
Load dependant cylinder lubricating drive	722
Load indicator	581
Locking device for fuel supply	400-20
Locking device for starting air	400-20, 401-20
Locking device for turning gear	321
Longitudinal section through engine	003
Low load	029
Low pressure oil system	840
Lubricating oil consumption (cylinder)	721, 722
Lubricating oil specification	042
Lubricating oil quills for cylinder liner	215
Lubricating system for turbocharger (see turbocharger instruction book)	
Lubricating system for crosshead	339

M

Main cylinders	Group 2
Main bearings	117
Maintenance, see separate "Maintenance Manual"	
Manual cut-out of fuel pumps	551
Manoeuvring	028
Manoeuvres, crash manoeuvres	400
Measuring instruments	924
Measures to prevent fires	051
Measures to prevent explosions	052
Misfiring	068

N

Needle valve, fuel injector nozzle needle	272
No-load running with propeller uncoupled	032
Non-return valve for cylinder lubrication	215
Non-return valve for scavenge air	641
Non-return valve on scavenge air receiver	641
Non-return valve for starting air	436
Normal running	024
Nozzles, fuel injector nozzles	272

O

Oil and water cut-out device	530
Oil consumption, cylinder oil	722
Oil pipes	840
Oil pressures	840, 025
Oil specifications for engines	042

ALPHABETICAL SUBJECT INDEX

O

Oil specifications for governor	511
Oil specifications for turbocharger, (see separate instruction manual)	
Oil system	840
Oil viscosity	042
Oilers, cylinder lubrication	721
Operating the engine	008
Operating problems, hints on operation	060
Operation, extended periods out of service	031
Operation on heavy oil	027
Operation with defective charge air cooler	035
Operation with defective turbocharger	034
Overhaul schedule, (see separate maintenance manual)	
Over speed, safety cut-out device (Pneumatic fuel pump cut-out device)	530

P

Pads, thrust bearing pads	120
Pipes for fuel injection system	877
Pipes for cooling water system	830
Pipes for exhaust system	811
Pipes for heating the fuel system	877
Pipes for lubricating oil system	840
Pipes for starting air system	869
Piston cooling, general	361, 830
Piston cooling gland	361
Piston cooling telescopic pipes	361
Piston cooling stand pipes	361
Piston, main piston	340
Piston rings	344
Piston rod connection the piston	340
Piston rod gland	231
Piston running hot	070
Piston underside	006, 051
Piston runs hot	070
Plunger stroke, fuel pump	551
Pneumatic engine control	400
Pneumatic logic box	463
Poor combustion	067
Ports, exhaust ports	214
Preface	000
Preparing the engine for extended periods out of service	031
Pressure, admissible pressures	025
Pressure, scavenge air pressure drops	066
Pressure, injection pressure for fuel injectors	272
Pressure, oil and water pressure safety device	025, 530
Pressure reducing unit	404
Prevention of explosions	052
Prevention of fires	051
Preventive measures against frost	031

ALPHABETICAL SUBJECT INDEX

P

Priming the fuel systems	022
Protective grid before turbine	811
Propeller law	007
Propeller uncoupled	032
Propeller unsuitable	007
Pump, fuel injection pump	551

Q

Quills, lubricating quills for cylinder liners	215
--	-----

R

Reciprocating pipes for piston cooling	361
Reduced fuel charge, switching over to..	034,551
Regulating linkage	581
Regulation, pneumatic control	400
Relief valve for scavenge air receiver	641
Relief valve for crankcase	052,148
Relief valve for cylinder cover	277
Relief valve for fuel injection pump	551
Relief valve for starting air system	400
Reversing servomotor	423
Reversing control valve	450
Reversing safety interlock	400,453
Revolution counter	481
Remote load indicator	924
Remote running direction indicator	924
Rings, piston rings	344
Rings, water guide ring on cylinder liner	
Rubber sealing rings, dimensions	043
Running direction indicator	924
Running direction safety interlock	453
Running the engine on heavy oil	027

S

Safety cut-out device, overspeeding of engine	530
Safety valves for fuel injection pump	551
Safety valves for starting air system	400

ALPHABETICAL SUBJECT INDEX

S

Scavenge air cooler	661
Scavenge air non-return valve	641
Scavenge air pressure drops	066
Scavenge air ports	214
Scraper groups for piston cooling glands	361
Sea is rough	030
Sectional drawings of engine	003
Servomotor, automatic fuel cutout servomotor	455
Servomotor, reversing servomotor	423
Service of engine (service instruction)	020
Shaft, eccentric shaft for fuel pumps	551
Shaft for vertical drive	413
Shims for connecting rod (compression)	330
Short description of engine	005
Silencer for turbocharger (see turbocharger instruction book)	
Smoking exhaust	067
Spaces, scavenge spaces	641
Spare parts for turbocharger (see turbocharger instruction book)	
Spare parts, general (see separate code book)	
Specification for fuel oil	027,041
Speed dropping	066
Speed droop	511
Speed setting lever (fuel lever)	400
Speed setting on governor	400,511
Stand pipes for piston cooling	361
Starting air shut off valve	436
Starting air control system general	400
Starting air pipes	869
Starting air control valve	434
Starting valve cam (Pilot starting valve cam)	431
Starting air pipe safety valve	869
Starting blocking device (pneumatic)	400
Starting air valves	274
Starting air distribution	431
Starting the engine	400,023
Stop the engine	036
Stopping engine over extended period of time	031
Summary of instructions for operation	008

ALPHABETICAL SUBJECT INDEX

T

Telescopic pipes for piston cooling	340,361
Temperatures (min.-max.)	025
Temperature of exhaust gas rises	066
Temperature of exhaust gas drops on one cylinder	066
Tensioning of principal bolted connections, (see Maintenance Manual)	
Thrust bearing	120
Thrust bearing pads	120
Thrust bolts for main bearings	117
Tie rods	191
Timing, fuel injection pumps	551
Tools, (see Maintenance Manual)	
Treatment of cooling water	053
Transmitter to remote load indicator	924
Transmitter to remote running direction indicator	924
Turbocharger (description) see separate instruction book	651
Turbocharger, running with defect	034
Turbocharger cleaning (washing instruction) see separate inst.book	
Turbocharger, protective grid before turbine	811
Turning gear	321

U

Uneven running of engine	068
Uncoupled propeller	032
Unsuitable propeller	007

V

Valve, control valve for fuel blocking	400-20
Valve, control valve for starting air blocking device	400-20,401-20
Valve, discharge valve for fuel pump	551
Valve, fuel injection	272
Valve, fuel injection nozzle	272
Valve, starting air control valve	434
Valve, relief valve for crankcase	142
Valve, relief valve on cylinder cover	277
Valve, relief valve for starting air	400
Valve, relief valve scavenge air receiver	051,641
Valve, relief valve fuel injection pump	551
Valve, reversing control valve	450
Valve, starting air valve	274
Valve (Stream valves in charge air receiver)	661
Valve, suction valve for fuel injection pump	551
Vertical drive	413
Viscosity, fuel	027,041
Viscosity, lubricating oil	042

ALPHABETICAL SUBJECT INDEX

W

Washing turbocharger in service	651
Water and oil safety cut-out device	530
Water, cooling water treatment	053
Water guide ring for cylinder liner	214
Water piping systems	830
Water separator (Charge air receiver)	670
Weight of individual parts	045
Wear, (see Maintenance Manual)	
Wheels for camshaft driving gear	411
Working piston	340
Working principle of the engine	006
WOODWARD governor	511
WOODWARD governor defect	511
Water guide ring in cylinder jacket	211

E X P L A N A T I O N

of the sectional views of the engine 003-20, -20a, -21, -21a and -21b

The cross- and longitudinal sectional views show an engine of the type RLB76.

In view of the fact that - in accordance with the number of cylinders - the engine can be equipped with exhaust gas turbochargers of different size and, furthermore, that the camshaft drive may be provided on the driving end or in the middle of the engine, the following provide views of various engine versions:

- 003-20 Cross sectional view of an engine with turbocharger
VTR 564
- 003-20a Cross sectional view of an engine with turbocharger
VTR 714
- 003-21 Longitudinal view of an engine with 4 to 6 cylinders,
w i t h o u t balancer.
Camshaft drive on the driving end of the engine.
- 003-21a Longitudinal view of an engine with 4 to 6 cylinders,
w i t h mass balancers on the driving end and at the
free end.
Camshaft drive on the driving end of the engine
- 003-21b Longitudinal view of an engine with 7 to 10 cylinders,
with camshaft drive in the middle of the engine.

The numbers used to designate the various engine components in the sectional views relate to the section in the operating manual in which they are described in greater detail.

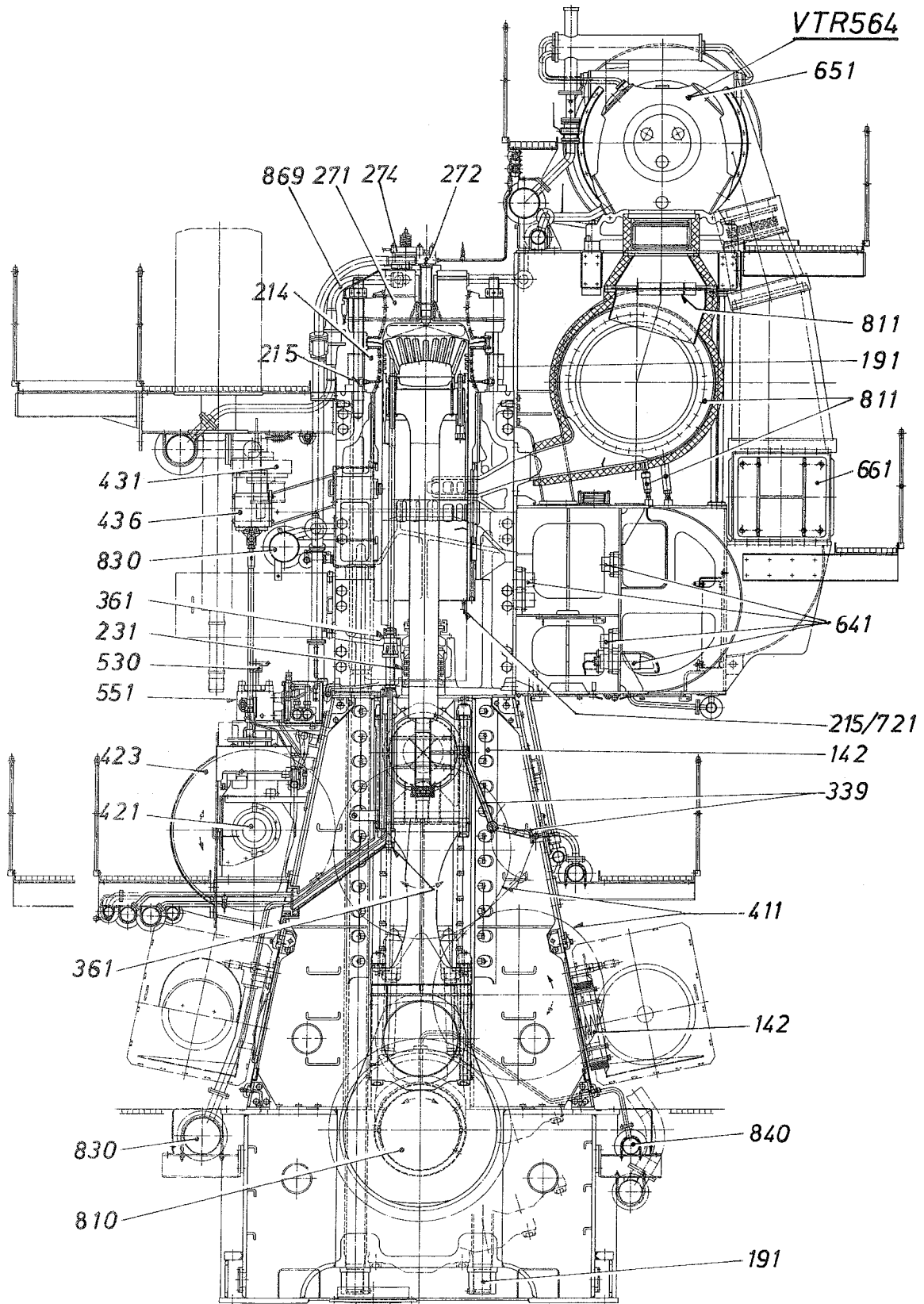

003-20a

