

DETROIT DIESEL



1063-7305

330 HP @ 1800 rpm

289 HP @ 1500 rpm

Generator Engine

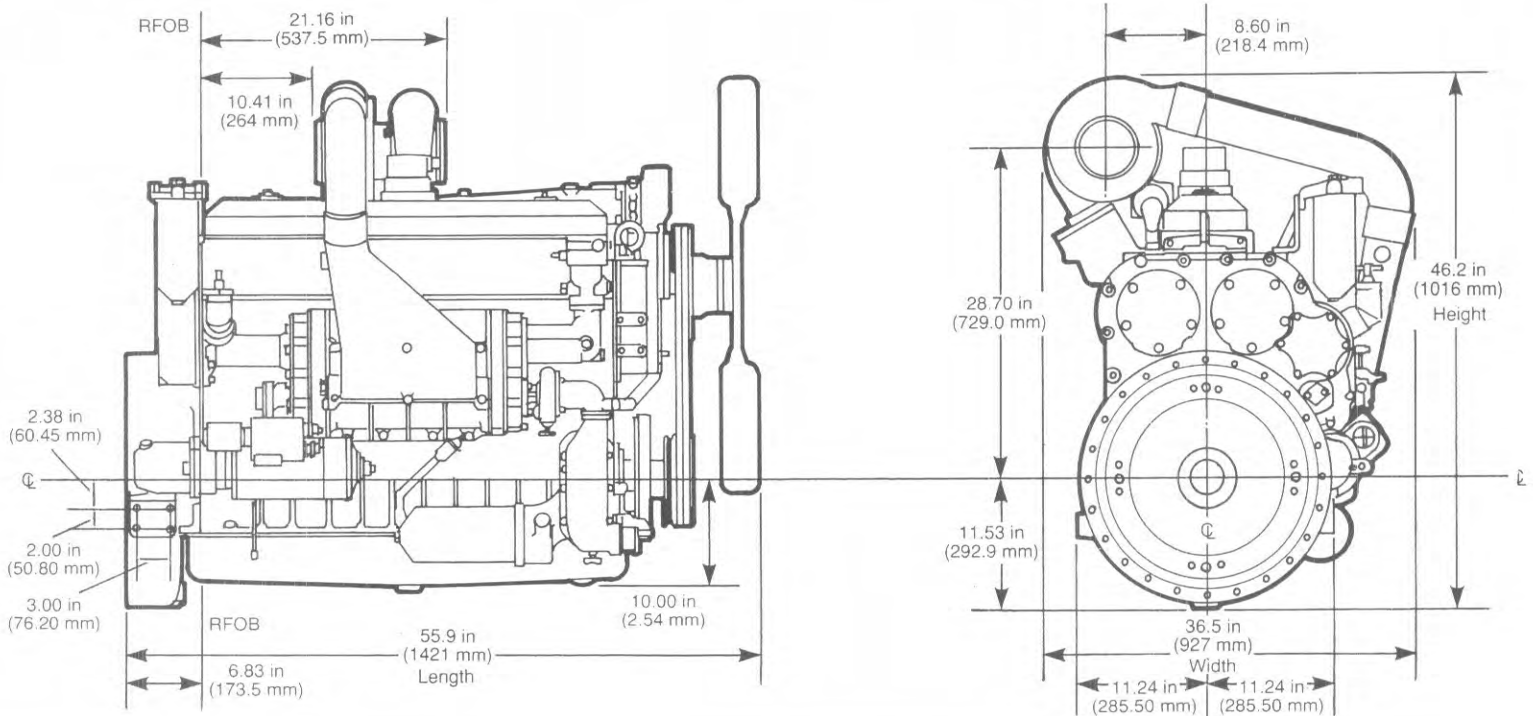

Basic Technical Data

Number of Cylinders: 6.

Cylinder Arrangement: In line.

Cycle: 2 stroke.

Induction System: Turbocharged.

Combustion System: Direct Injection.

Bore: 4.25 in (108 mm).

Stroke: 5.0 in (127.0 mm).

Compression Ratio: 17.0:1.

Cubic Capacity: 426 in³ (6.99 liters).

Direction of Rotation: Clockwise, viewed from the front.

Firing Order: 1, 5, 3, 6, 2, 4.

Total Weight (dry): 2240 lbs (1016 kg).

Total Weight (wet): 2339 lbs (1061 kg).

Overall Dimensions: Height 46.2 in (1016 mm);
Length 55.9 in (1421 mm); Width 36.5 (927 mm).

Moment of Inertia (wr²): Engine 3.19 lb-in-s² (0.36 kg m²);
Flywheel 27.13 lb-in-s² (3.65 kg m²).

Governing: Electronic, speed control.

Speed Variation at Constant Load: ± 0.25%

Engine Performance Curve, Standby Rating: E4-1065-32-8.

Prime Rating: E4-1065-32-9.

Engine Installation Drawing: 2SA397 (5147477).

Performance

Maximum Overspeed Limit: 2300 rpm.

Average Sound Pressure Level for Bare Engine (Without Inlet and Exhaust) at 1 meter: 1800 rpm 99.2 dBA;
1500 rpm 100 dBA.

Note: All data based on operation under ISO 3046, BS 5514, or SAE J1349.

Test Conditions: Rated prime power output shown represents engine performance capabilities at ambient conditions equivalent to ISO 3046, BS 5514: 77°F (25°C) air inlet temperature; 29.5 in. Hg (100 kPa) total barometric pressure; 30% relative humidity. Rated standby power shown represents engine performance capabilities at ambient conditions equivalent to SAE J1349: 77°F (25°C) air inlet temperature; 29.31 in. Hg (99 kPa) dry barometer.

Indicated performance is based on minimum intake and exhaust restrictions.

All ratings certified within ± 5%.

If the engine is to operate in ambient conditions other than the test conditions then suitable adjustments must be made for any change in inlet air temperature, barometric pressure or humidity. For details refer to Detroit Diesel.

Diesel Fuel: To conform to ASTM D975 66T Number 2D or BS 2869: 1983 Class A2.

Lubricating Oil: A monograde SAE 40 lubricating oil must be used which conforms with specification MIL-L-2104D or API-CD-II.

Technical Data

Item	Units	Type of operation and application			
		Prime ¹		Standby ^{2, 5}	
		50 Hz	60 Hz	50 Hz	60 Hz
Engine speed	rpm	1500	1800	1500	1800
Rated engine power	bhp (kW)	250 (186)	286 (214)	289 (216)	330 (246)
Brake mean effective pressure	lbf/in ² (kPa)	155.1 (1069)	147.8 (1019)	179.3 (1236)	170.6 (176)
Piston speed	ft/min (m/min)	1250 (381)	1500 (457)	1250 (381)	1500 (457)
Engine coolant flow	US gal/min (Liter/min)	75 (284)	88 (333)	75 (284)	88 (333)
Combustion air flow	ft ³ /min (m ³ /min)	840 (23.8)	1000 (28.3)	920 (26.1)	1080 (30.6)
Exhaust gas flow	ft ³ /min (m ³ /min)	1770 (50.1)	2010 (56.9)	1990 (56.4)	2240 (63.4)
Exhaust gas temperature	°F (°C)	670 (354)	620 (327)	700 (371)	655 (346)
Fan power ³	bhp (kW)	4.0 (6.7)	15.0 (11.2)	9.0 (6.7)	15.0 (11.2)
Cooling fan airflow	ft ³ /min (m ³ /min)	13000 (368)	15470 (438)	13000 (368)	15470 (438)
Heat from fuel	Btu/min (kW)	27218 (479)	31535 (555)	31749 (558)	36556 (643)
Heat to power	Btu/min (kW)	10600 (186)	12126 (213)	12254 (216)	13992 (246)
Heat to coolant	Btu/min (kW)	7630 (134)	8870 (156)	8810 (155)	10230 (180)
Heat to exhaust	Btu/min (kW)	7898 (139)	9419 (165.6)	9396 (165)	11014 (194)
Heat to radiation	Btu/min (kW)	1090 (19.2)	1120 (19.7)	1290 (22.7)	1320 (23.2)

¹ Equivalent to ISO-3046 Continuous Power

² Equivalent to ISO-3046 Fuel Stop Power

³ With standard option fan.

⁴ Based on LHV of Fuel = 18370 BTU/lb

⁵ It is recommended that all ancillary engine systems be designed for maximum engine capability.

Cooling System

Coolant:

Maximum static pressure head at pump:
50 ft. H₂O (149 kPa).

Minimum temperature to engine: 160°F (71°C).

Temperature rise across engine: 10°F (5.5°C).

Maximum permissible external system
resistance: 5 psi (3.4 kPa).

Standard Option Fan:

Diameter: 36" (914 mm).

Drive Ratio: 0.77:1

Number of Blades: 8

Thermostat:

Operation range: 170-185°F (78-86°C).

Electrical System

Battery Charging System:

Type: Negative ground.

Alternator: Delco-Remy.

Starter motor: Delco-Remy.

Recommended Battery Capacity			
Temperature		SAE J537 Cold cranking amperes	
°F	°C	12V	24V
Over 32	Over 0	950	475
Under 32	Under 0	1250	625

DETROIT DIESEL

CORPORATION



13400 Outer Drive, West / Detroit, Michigan 48239-4001

Telephone: 313-592-5000

Telex: 4320091 / TWX: 810-221-1649

FAX: 313-592-7288

Exhaust System

Maximum Back Pressure for Total System:

1800 rpm, 2.0 in Hg (6.8 kPa);

1500 rpm, 1.4 in Hg (4.7 kPa).

Inside Diameter of Engine Exhaust Outlet:

5.0 in (127 mm)

Lubrication System

Lubricating Oil Capacity: Total system

28 qt (26.5 litres); Sump only 26 qt (24.6 litres).

Normal Operation Angles: Front up 13°,

Front down 4°, Side to side, 13°.

Lubricating Oil Pressure: At rated speed

1800 rpm 54 psi (372 kPa);

1500 rpm 50 psi (345 kPa).

Lubricating Oil Temperature:

At normal operation 200-235°F (93-113°C),

Maximum 250°F (121°C).

Lubricating Oil Consumption as a Percentage

of Fuel Consumption: 0.5% maximum.

Recommended SAE viscosity grades:

	API Symbol:	SAE Viscosity Grade: 40.
		API Classification: CD-II
		Military Spec.: Mil-L-2104D
		Sulfated Ash: Less Than 1.0%

Certain engine operating conditions may require exceptions to this recommendation:

- For continuous high temperature operation (over 100°F ambient or 200°F Coolant Out) the use of an SAE grade 50 lubricant in all series, two-cycle DDC engines is recommended.
- At ambient temperatures below freezing where starting aids are not available or at very cold temperatures (0 to -25°F), the use of multiviscosity grade 15W-40 or monograde SAE 30 lubricants will improve startability. **Exception: Do not use these lubricants in two-cycle marine engines or DDC Series 149 engines under any circumstances.**

Mountings

Maximum Bending Moment at Rear Face of Engine Block: 0 lbf-ft (0 Nm).

Position of Center of Gravity (dry engine):

Forward from rear face of block, 22.9 in. (582 mm);

Above crankshaft center line, 5.1 in. (129.5 mm);

Left of center line, 1.5 in. (38.1 mm).

Fuel System

Type of Injection System: Direct.

Fuel Injection Pump: Not Applicable.

Fuel Injector:

Type: Unit Injector.

Fuel Lift Pump:

Delivery/hour:

1800 rpm, 88.1 gal. (333.4 liters);

1500 rpm, 81.8 gal. (309.8 liters).

Pressure: 45 psi (310 kPa).

Maximum pump suction:

Clean System 6.0 in Hg (20 kPa);

Dirty System 12.0 in Hg (41 kPa).

Fuel Filter Micron Size

Primary, Micron: 30

Secondary, Micron: 12

Governor Type: Barber-Colman 8000, Electronic.

Induction System

Maximum Air Intake Restriction at Engine:

1800 rpm, Clean filter 8.7 in H₂O (2.16 kPa);

Dirty filter 14.5 in H₂O (3.6 kPa).

1500 rpm, Clean filter 6.2 in H₂O (1.54 kPa);

Dirty filter 10.5 in H₂O (2.6 kPa).

Recommended Inside Diameter of Intake Pipe:

5.0 in. (127 mm)